

Authorised Channel Partner

SALOC[®]
The Integrated Power System

SALOC Technologies Pvt. Ltd.,

#274/14, New Guddada halli, Mysore Road,
Bangalore - 560026, Karnataka .

Phone : 91-80-2675 5000

Mobile / WhatsApp : 91-98454 55258 / 96864 47828

Mail to : sales@saloc.in, surendran@saloc.in

Website : www.saloc.in



Jan
2023
Edition

SIMOTICS 1LE7 Motors

Redefining the world of energy efficiency.

Presenting a wide range of energy efficient low voltage motors.

www.siemens.co.in/lv-motors

SIEMENS

SIMOTICS – the most comprehensive range of motors

The history of today's most comprehensive range of motors worldwide started about 150 years ago in 1866 when Werner von Siemens developed the dynamo-electric principle. This principle allowed powerful electric motors to be designed and built, thereby creating the basis for their widespread use in industry today. Since then, motor development has been one of the core businesses of the company, and with greater than a century worth of experience, Siemens sets the pace when it comes to innovative motor technology. Today, millions of Siemens motors are efficiently powering machines and equipment in industrial facilities around the world. In all sectors, applications and power classes. Siemens energy-efficient low-voltage motors with high dynamic performance have proven themselves in use, and are attractive as a result of their quality, efficiency and compactness. The new SIMOTICS 1LE7 range of motors are offered in line with the range of motors offered worldwide from the house of Siemens.

SIMOTICS stands for:

- More than 150 years of motor production worldwide and 55 years of motor production in India
- Optimum solutions in all sectors, regions and power classes
- Innovative motor technology with the highest quality and reliability
- Highest dynamic performance, precision and efficiency, with an optimum degree of compactness
- Integration of the motors in the drive train to create an overall system
- The global network of skill sets and round the clock service worldwide

CE mark will be stamped on the nameplate only if the motor conforms to the requirements of COMMISSION REGULATION (EU) 2019/1781 of 1st October 2019 and its amendment issued vide COMMISSION REGULATION (EU) 2021/341 of 23rd February 2021 of the European Union.

SIMOTICS 1LE7 motors have a rugged cast-iron housing, which means they are also suitable for use in harsh to very harsh environments. With a wide power range from 0.12kW (in 8pole) to 225kW (in 1LE7 extended output). SIMOTICS 1LE7 motors are the basis for machine and plant builders and owners who require a motor for flexible requirements and conditions of use.

Available motor variants:

- Induction motors, optimized for line operation
 - in efficiency classes IE3, IE2 (in frame size 71 to 315) & IE4 (in frame size 180 to 315)
 - standards-compliant version
 - as a 2, 4, 6, 8-pole version
- Different types of construction, voltage versions, and a very wide variety of options/add-ons for precise adaptation of the motors to application and customer-specific requirements.



IE efficiency classes

The efficiency classes are grouped according to the following nomenclature (IE = International Efficiency):

- IE2 (High Efficiency)
- IE3 (Premium Efficiency)
- IE4 (Super Premium Efficiency)

Nominal efficiencies (required for qualifying to a defined efficiency class) according to IS 12615 :2018 are

Rated power $P_{rated, 50Hz}$ kW	Efficiency η in %															
	2 Pole				4 Pole				6 Pole				8 Pole			
	Frame size	IE2 – High Efficiency	IE3 – Premium Efficiency	IE4 – Super Premium Efficiency	Frame size	IE2 – High Efficiency	IE3 – Premium Efficiency	IE4 – Super Premium Efficiency	Frame size	IE2 – High Efficiency	IE3 – Premium Efficiency	IE4 – Super Premium Efficiency	Frame size	IE2 – High Efficiency	IE3 – Premium Efficiency	IE4 – Super Premium Efficiency
0.12	56	53.6	60.8	66.5	63	59.1	64.8	69.8	63	50.6	57.7	64.9	71	39.8	50.7	62.3
0.18	63	60.4	65.9	70.8	63	64.7	69.9	74.7	71	56.6	63.9	70.1	80	45.9	58.7	67.2
0.25	63	64.8	69.7	74.3	71	68.5	73.5	77.9	71	61.6	68.6	74.1	80	50.6	64.1	70.8
0.37	71	69.5	73.8	78.1	71	72.7	77.3	81.1	80	67.6	73.5	78.0	90S	56.1	69.3	74.3
0.55	71	74.1	77.8	81.5	80	77.1	80.8	83.9	80	73.1	77.2	80.9	90L	61.7	73.0	77.0
0.75	80	77.4	80.7	83.5	80	79.6	82.5	85.7	90S	75.9	78.9	82.7	100L	66.2	75.0	78.4
1.1	80	79.6	82.7	85.2	90S	81.4	84.1	87.2	90L	78.1	81.0	84.5	100L	70.8	77.7	80.8
1.5	90S	81.3	84.2	86.5	90L	82.8	85.3	88.2	100L	79.8	82.5	85.9	112M	74.1	79.7	82.6
2.2	90L	83.2	85.9	88.0	100L	84.3	86.7	89.5	112M	81.8	84.3	87.4	132S	77.6	81.9	84.5
3.7	100L	85.5	87.8	89.7	112M	86.3	88.4	90.9	132S	84.3	86.5	89.3	160M	81.4	84.5	86.8
5.5	132S	87.0	89.2	90.9	132S	87.7	89.6	91.9	132M	86.0	88.0	90.5	160M	83.8	86.2	88.3
7.5	132S	88.1	90.1	91.7	132M	88.7	90.4	92.6	160M	87.2	89.1	91.3	160L	85.3	87.3	89.3
11	160M	89.4	91.2	92.6	160M	89.8	91.4	93.3	160L	88.7	90.3	92.3	180L	86.9	88.6	90.4
15	160M	90.3	91.9	93.3	160L	90.6	92.1	93.9	180L	89.7	91.2	92.9	200L	88.0	89.6	91.2
18.5	160L	90.9	92.4	93.7	180M	91.2	92.6	94.2	200L	90.4	91.7	93.4	225S	88.6	90.1	91.7
22	180M	91.3	92.7	94.0	180L	91.6	93.0	94.5	200L	90.9	92.2	93.7	225M	89.1	90.6	92.1
30	200L	92.0	93.3	94.5	200L	92.3	93.6	94.9	225M	91.7	92.9	94.2	250M	89.8	91.3	92.7
37	200L	92.5	93.7	94.8	225S	92.7	93.9	95.2	250M	92.2	93.3	94.5	280S	90.3	91.8	93.1
45	225M	92.9	94.0	95.0	225M	93.1	94.2	95.4	280S	92.7	93.7	94.8	280M	90.7	92.2	93.4
55	250M	93.2	94.3	95.3	250M	93.5	94.6	95.7	280M	93.1	94.1	95.1	315S	91.0	92.5	93.7
75	280S	93.8	94.7	95.6	280S	94.0	95.0	96.0	315S	93.7	94.6	95.4	315M	91.6	93.1	94.2
90	280M	94.1	95.0	95.8	280M	94.2	95.2	96.1	315M	94.0	94.9	95.6	315L#	91.9	93.4	94.4
110	315S	94.3	95.2	96.0	315S	94.5	95.4	96.3	315M#	94.3	95.1	95.8	315L#	92.3	93.7	94.7
132	315M#	94.6	95.4	96.2	315M#	94.7	95.6	96.4	315L#	94.6	95.4	96.0	315L#	92.6	94.0	94.9
160	315L#	94.8	95.6	96.3	315L#	94.9	95.8	96.6	As per manufacturer catalogue	94.8	95.6	96.2	As per manufacturer catalogue	93.0	94.3	95.1
200 ... 1000	As per manufacturer catalogue	95.0	95.8	96.5	As per manufacturer catalogue	95.1	96.0	96.7	As per manufacturer catalogue	95.0	95.8	96.3	As per manufacturer catalogue	93.5	94.6	95.4

Output to frame size relation is maintained in accordance with IS 1231 for all motors except those marked as #, wherein the frame size indicated is 'preferred size'.

Note:

All efficiency classes are stated with reference to 50 Hz data - (unless specified otherwise) when motor is operated on a sinusoidal supply.

To protect the motor against corrosion and external influences, high-quality paint systems are available in various colours.

Additional identification code –Z with order code							
Standard version	S01 (DFT 60µ)	S07+Y57 (DFT 90µ)	S07+Y57 (DFT 120µ) Y57 = 120µ	S07+Y57 (DFT 180µ) Y57 = 180µ	* S03+ S06+ Y57 (DFT 180µ) Y57 = 180µ	* S03+ S06+ Y57 (DFT 240µ) Y57 = 240µ	* S04+ S06+ Y57 (DFT 295µ) Y57 = 295µ
Paint finish, suitability of paint finish for climate group in accordance with IEC 60721-2-1							
Standard paint finish	Unpainted, motor primed	Epoxy based Paint - Standard paint thickness	Epoxy based Paint - Special paint thickness DFT 120µ	Epoxy based Paint - Special paint thickness DFT 180µ	Special finish for use onshore sea air resistant	Special finish for use onshore sea air resistant	Special paint thickness for offshore use
Use							
	The motors can be supplied with just a (red oxide) primer coat on request.	Moderate (extended) for indoor and outdoor installation under a roof not directly exposed to weather conditions	Moderate (extended) for indoor and outdoor installation under a roof not directly exposed to weather conditions	Worldwide (global) for outdoor installation in direct sunlight and/or exposed to weather conditions	Sea-air resistant paint finish with final coat polyurethane paint (DFT 180µ)	Sea-air resistant paint finish with final coat polyurethane paint (DFT 240µ)	Paint finish for off-shore use with final coat polyurethane paint (DFT 295µ)
		Corrosive category C2 (low) according to ISO 12944 -2	Corrosive category C2 (medium) according to ISO 12944 -2	Corrosive category C3 (medium) according to ISO 12944 -2	Worldwide (global) for outdoor installation in direct sunlight and/or exposed to weather conditions.	Recommended for indoor or outdoor installation directly exposed to weather conditions, industrial climate with moderate SO2 exposure, VIK requirements, inshore maritime climate, but not offshore maritime climate e.g. for crane drives and in the paper industry	Recommended for outdoor installations exposed to direct weather conditions, industrial climate with moderate SO2 exposure, and offshore maritime climate, e.g. for crane drives.
					Corrosive category C3 (medium) according to ISO 12944 -2	Corrosive category C4 (medium) according to ISO 12944 -2	Corrosive category C5-I and C5-M (medium) according to ISO 12944 -2

Notes:

1. Paint thickness needs to be specified by means of plain text irrespective of whether it is standard or special.
2. S06 - Final Coat Polyurethane is mandatory with S03 or S04. S06 is not possible to be ordered separately.
3. H07 - Non-rusting external hardware is mandatory with S03 or S04. H07 can be separately order even without S03 or S04. The separate price for H07 is available against the option.

Paint finish in other standard RAL colours – Order code Y53

RAL No.	Colour name	RAL No.	Colour name
3007	Black red	7000	Squirrel gray
5002	Ultramarine blue	7001	Silver gray
5007	Brilliant blue	7004	Signal gray
5009	Azure blue	7011	Iron gray
5010	Gentian blue	7016	Anthracite gray
5015	Sky blue	7022	Umbra gray
5017	Traffic blue	7031	Blue gray
5018	Turquoise blue	7032	Pebble gray
5019	Capri blue	7033	Cement gray
6011	Reseda green	7035	Light gray
6021	Pale green	9005	Jet black

The following weakly covering paints must be applied at least twice owing to their poor opacity. The standard paint finish for these colours is not possible and must be ordered with **S07**, **S03**, or **S04**.

RAL No.	Colour name
1002	Sand yellow
1013	Oyster white
1015	Light ivory
1019	Gray beige
2003	Pastel orange
2004	Pure orange
3000	Flame red
5012	Light blue
6019	Pastel green
9001	Cream white
9002	Gray white

ISS Paint Shade for Y56

Shade	Colour name
631	Light Grey
632	Dark Admiralty Grey
697	Light Admiralty Grey
692	Smoke Grey
275	Opaline Green
536	Fire Red
538	Post Office Red
166	French Blue
174	Oriental Blue
217	Sea Green
221	Brilliant Green
281	Apple Green
635	Lead
693	Aircraft Grey
694	Dove Grey

Paint finish in special RAL colours – Order code Y56

RAL No.	Colour name	RAL No.	Colour name
3004	Purple red	6032	Signal green
3011	Brown red	6034	Pastel turquoise
3015	Light pink	7005	Mouse gray
3020	Traffic red	7009	Green gray
4005	Blue lilac	7012	Basalt gray
5000	Violet blue	7015	Slate gray
5001	Green blue	7023	Concrete gray
5003	Sapphire blue	7036	Platinum gray
5005	Signal blue	7037	Dusty gray
5011	Steel blue	7038	Agate gray
5013	Cobalt blue	7039	Quartz gray
5014	Pigeon blue	7040	Window gray
5020	Ocean blue	7042	Traffic gray A
5021	Water blue	7044	Silk gray
5022	Night blue	7045	Telegray 1
5023	Distant blue	7046	Telegray 2
6000	Patina green	7047	Telegray 4
6001	Emerald green	8012	Red brown
6002	Leaf green	8025	Pale brown
6005	Moss green	8028	Terra brown
6009	Fir green	9003	Signal white
6010	Grass green	9004	Signal black
6016	Turquoise green	9006	White aluminum
6017	May green	9007	Gray aluminum
6018	Yellow green	9010	Pure white
6024	Traffic green	9011	Graphite black
6026	Opal green	9016	Traffic white
6029	Mint green	9017	Traffic black

The following weakly covering paints must be applied at least twice owing to their poor opacity. The standard paint finish for these colours is not possible and must be ordered with **S07**, **S03**, or **S04**.

RAL No.	Colour name
1003	Signal yellow
1004	Golden yellow
1006	Maize yellow
1007	Daffodil yellow
1012	Lemon yellow
1014	Ivory
1018	Zinc yellow
1021	Rape yellow
1023	Traffic yellow
1028	Melon yellow
1032	Broom yellow
1033	Dahlia yellow
2008	Bright red orange
2009	Traffic orange
2010	Signal orange
3002	Carmine red
5024	Pastel blue
6027	Light green

Packing Weight and Dimension

For motors		Type of construction IM B3				Type of construction IM B5	
Frame size	Type 1LE7...-	TB Top		TB LHS/RHS		TB Top/LHS/RHS	
		Packing Weight kg	LxBxH mm	Packing Weight kg	LxBxH mm	Packing Weight kg	LxBxH mm
71		1	300x250x285	1	300x250x285	1	300x250x285
80		1	355x250x310	1	355x250x310	1	355x250x310
90 S		2	455x300x330	2	455x300x330	2	455x300x330
90 L		2	455x300x330	2	455x300x330	2	455x300x330
100 L		3	490x320x370	3	490x320x370	3	490x320x370
112 M		3.2	510x335x400	3.2	510x335x400	3.2	510x335x400
132 S		4	595x375x480	4	595x375x480	4	595x375x480
132 M		4.4	640x375x480	4.4	640x375x480	4.4	640x375x480
160 M		50	810x444x730	65	810x670x550	55	810x480x730
160 L		50	810x444x730	65	810x670x550	55	810x480x730
180 M		55	860x474x770	70	860x690x710	60	860x495x770
180 L		55	860x474x770	70	860x690x710	60	860x495x770
200 L		70	890x538x825	85	890x750x775	70	890x540x825
225 S		100	1030x586x930	115	1030x850x815	115	1030x635x930
225 M		100	1030x586x930	115	1030x850x815	115	1030x635x930
250 M		135	1118x700x904	160	1118x904x854	150	1118x739x900
280 S		165	1188x751x1014	195	1188x934x954	160	1188x749x1014
280 M		175	1298x751x1014	205	1298x934x954	170	1298x749x1014
315 S		195	1308x798x1124	235	1308x1044x1044	265	1308x904x1089
315 M		210	1478x798x1124	250	1478x1044x1044	285	1478x904x1089
315 L		230	1628x798x1124	270	1628x1044x1044	300	1633x904x1089

Applicable standards and specifications

The SIMOTICS 1LE7 motors comply with the various Indian Standards and also some IEC 60034 series of international product standards for rotating electrical machines and, in particular, those parts that are listed in the table below.

Title	IS standards	IEC	Title	IS standards	IEC
General specifications for rotating electrical machines	IS 15999 (Part 1)	IEC 60034-1	Built-in thermal protection	–	IEC 60034-11
Specification of the losses and efficiency of rotating electrical machines	IS 15999 (Part 2 SEC 1)	IEC 60034-2-1	Noise limits of rotating electrical machines	IS 12065	IEC 60034-9
General-purpose three-phase induction motors having standard dimensions and powers	IS 1231 IS 2223	IEC 60072 Mounting dimensions and power series only (no assignment of frame size to power)	IEC standard voltages	IS 12360	IEC 60038
Terminal designations and direction of rotation for electrical machines	IS/IEC 60034 (Part 8)	IEC 60034-8	Methods of cooling of rotating electrical machines (IC code)	IS 6362	IEC 60034-6
Designation for types of construction, mounting, and terminal box position (IM code)	IS 1231 IS 2223 Construction IS 2253	IEC 60034-7	Vibration severity of rotating electrical machines	IS 12075	IEC 60034-14
			Degrees of protection for rotating electrical machines (IP code)	IS/IEC 60034-5	IEC 60034-5
			International efficiency classes for rotating electrical machines (IE code)	IS 12615	IEC 60034-30-1

Tolerances for electrical data

According to IEC 60034-1, the following tolerances are permitted:

According to IS/IEC 60034-1 (or IS 15999-1).

Efficiency η at

$$P_{\text{rated}} \leq 150 \text{ kW: } -0.15 \times (1 - \eta)$$

$$P_{\text{rated}} > 150 \text{ kW: } -0.1 \times (1 - \eta)$$

Where η is a decimal number.

$$\text{Power factor: } \frac{1 - \cos\phi}{6}$$

- Minimum absolute value: 0.02
- Maximum absolute value: 0.07

Slip $\pm 20\%$ (for motors $< 1 \text{ kW}$ $\pm 30\%$ is admissible)

Locked-rotor current : $+20\%$

Locked-rotor torque : -15% to $+25\%$

Breakdown torque : -10%

Moment of inertia (or GD^2) : $\pm 10\%$

Voltage and frequency variation

As per IS 12615, motors shall be capable of delivering rated output with

- terminal voltage differing from its rated value by not more than $\pm 10\%$
- frequency differing from its rated value by not more than $\pm 5\%$
- combined variation - The sum of absolute percent variation of (a) and (b) not exceeding 10% .

In the case of continuous operation at the extreme voltage limits specified at (a) and (b), the temperature rise limits of the winding specified in IS 15999 (Part 1)/IEC 60034-1 shall not exceed by more than 20 K . In such cases, motor may be designed with higher class of insulation. Motors operated under the extreme conditions of voltage and/or frequency specified in (a) and (b), the performance values given in the selection tables may not necessarily comply with IS 12615.

For some non-standard voltages at 50 or 60 Hz, order codes are specified. They are ordered by specifying the code digit **9** for voltage in the 12th position of the MLFB as well as the code digit **0** in the 13th position of the MLFB and the corresponding order code.

M1Y Non-standard rated voltage between 220 V and 690 V (voltages outside this range are available on request).

Order codes for other rated voltages are listed under "Order suffixes" in the "Selection and ordering data" as well as "Special versions" under "Voltages".

Supplementary data

Supplementary data (maximum of 20 characters) can be indicated on the rating plate or additional rating plate and on the packaging label, order code **Y84**.

An additional rating plate for customer specifications is also possible, additional text: 2 lines of 20 characters each, order code **Y82**.

An additional rating plate with deviating rating plate data can also be ordered (only for ratings such as voltage, power, speed), order code **Y80**.

Examples of rating plate with motor type

Standard rating plate (Stainless Steel) for IEC motors and motors conforming to IS 12615

SIEMENS											
Made in India											
3 ϕ Motor, 7CV3314B, 1LE75033AB434AA4-Z KW 191165 65206800											
IEC60034-1		315L		IMB3		IP55					
1160kg		Th.Cl. 155 (F) -20°C <= TAMB <= 50°C									
DE		Bearing		UNIREX - N3						NE	
6319-C3		40g		Interval 6000h						6319 - C3 INS	
40g											
V	Hz	A	kW	PF	NOM.EFF	rpm	IE-CL				
400 Δ	50	277	160	0.87	95.9	1489	IE3				
690Y	50	160	160	0.87	95.9	1489	IE3				
440 Δ	60	251	160	0.87	96.2	1790	IE3				

SIEMENS											
Made in India											
3 ϕ Motor, 7CV3312A, 1LE75033AA235AA4-Z KW 190865 65180137											
IEC60034-1		315M		IMB3		IP55					
906kg		Th.Cl. 155 (F) -20°C <= TAMB <= 50°C									
DE		Bearing		UNIREX - N3						NE	
6316-C3		30g		Interval 3000h						6316-C3	
30g											
V %	Hz %	A	kW	PF	NOM.EFF	rpm	IE-CL	R 12615			
415 $\Delta \pm 10$	50 ± 5	211	132	0.91	95.6	2982	IE3	 <small>CMIL 7800027912</small>			

Efficiency and power factor

The nominal efficiency (η) and the power factor ($\cos\phi$) for each rated power are listed in the selection tables in the individual sections of this catalogue.

Rated speed and direction of rotation

The rated speeds are applicable for the rated data. The synchronous speed changes proportionally with the line frequency. The motors are suitable for clockwise and counter-clockwise rotation.

When U1, V1, W1 are connected to L1, L2, L3 the motor rotates clockwise when viewing the drive shaft extension as a standard practice. Counter-clockwise rotation is achieved by swapping any of the two phases.

Rated torque

The rated torque in Nm delivered at the motor shaft is

$$T = \frac{9550 \times P}{n}$$

P Rated power in kW

n Speed in rpm

Torque in kgf.m can be calculated by dividing the torque in Nm by 9.80665.

Note:

If the voltage deviates from its rated value within the admissible limits, the locked-rotor torque, the pull-up torque and the breakdown torque vary approximately in square proportion to the voltage, but the locked-rotor current varies approximately linearly.

In the case of squirrel-cage motors, the locked-rotor torque and breakdown torque are listed in the selection tables as multiples of the rated torque.

Preferred practice is to start squirrel-cage motors directly on line. The torque class indicates that with direct-on-line starting, even if there is an undervoltage of -10 %, it is possible to start up the motor against a constant load torque of

- 160 % for KL 16
- 130 % for KL 13
- 100 % for KL 10

of the rated torque.

DURIGNIT IR 2000 insulation system

The DURIGNIT IR 2000 insulation system consists of high quality enamel wires and insulating sheet materials in conjunction with temperature resistant resin impregnation.

This ensures that these motors will have a high mechanical and electrical strength, high service value, and a long lifetime. The insulation system protects the winding to a large degree against aggressive gases, vapours and dust. It can withstand the usual vibration stressing.

Please enquire about extreme applications.

Insulation systems for converter operation

Frame size 71 to 225 - The SIMOTICS motors can be operated in their standard version up to maximum converter input voltage of 480V.

Frame size 250 to 315 - The SIMOTICS motors can be operated in their standard version up to maximum converter input voltage of 500V.

Frame size 180 to 225 - For higher converter input voltages, $480V < U_N \leq 690V$, special insulation system (PREMIUM) is required, please enquire.

Frame size 250 to 315 - For higher converter input voltages, $500V < U_N \leq 690V$, special insulation system (PREMIUM) is required. The premium insulation scheme may result in drop in efficiency class in some motors.

Bearing insulation/shaft grounding brushes

To avoid damage to bearings due to bearing currents, we recommend bearing insulation at the non-drive end (NDE) for frame size 225 and larger (order code **L53**). It is mandatory to provide insulated bearing on non-driving end (NDE) for frame size 250 and above. Insulated bearing for frame size 180 & 200 shall be offered against enquiry.

In most cases, NDE bearing insulation provides sufficient protection against damage to bearings due to bearing currents.

In rare cases, depending on the application and system, it may be necessary to take further measures on the converter or motor. On the motor side, shaft grounding brushes (order code **L52** for frame size 280 and 315 can be provided. Please enquire for option L52.

The EMC guidelines must always be complied with when the drive system is installed.

Thermal utilization of the motor

When motors are operated on a converter, additional losses occur due to the harmonics in the motor currents, which, depending on the permissible winding temperature, can make it necessary to reduce the torque (de-rate the motor). For operation on SINAMICS converters, the permissible torque values can be obtained from SPC.

For operation on SINAMICS converters with the power ratings specified in the catalogue, the motors are used according to temperature class 155 (F), i.e. in this case neither a service factor > 1 nor an increased coolant temperature is possible (order codes **N01**, **N02** and **N03** cannot be ordered).

Restarting against residual field and opposite phase

All motors can be restarted against 100 % residual field after a line voltage failure.

Winding and insulation version with regard to temperature class

At rated power with line fed operation, most of the motors have utilization in accordance with temperature class B (130°C).

Temperature class 155 (F), utilized according to 155 (F), with service factor (SF)

According to the selection table, at rated power and rated voltage, all 1LE7 motors in line operation have a service factor of 1.15 with few exceptions. Please enquire.

Order code **N01**

Temperature class 155 (F), utilized according to 155 (F), for higher power

When utilized according to temperature class 155 (F), the rated power specified in the selection and ordering data can be increased by 15% with few exceptions. Please enquire.

Order code **N02**

Temperature class 155 (F), utilized acc. to 155 (F), with increased coolant temperature

With power rating as defined in the catalogue and line operation, coolant temperature is permitted to rise to 55°C with few exceptions. Please enquire.

Order code **N03**

The service factor (SF) is not indicated on the rating plate for order codes **N02** and **N03**.

For converter operation at the rated power specified in the catalogue, the motors are utilized according to temperature class 155 (F). Order codes N01, N02, and N03 are not possible.

Temperature class 155 (F), utilized acc. to 130 (B), coolant temperature 55°C, (Applicable for 1LE76) in IE2 and IE3

1LE7 motors with one step lower output in versions 1LE76 can be ordered according to temperature class 155 (F) for utilization according to temperature class 130 (B) and a maximum coolant temperature of 55°C.

Order code **N07**

Temperature class 155 (F), utilized acc. to 130 (B), coolant temperature 60°C, derating approx. 10 %

Motor series 1LE7 can be ordered according to temperature class 155 (F) for utilization according to temperature class 130 (B) and a maximum coolant temperature of 60°C with derating of 10 %. Please enquire before ordering as this calls for certain changes in specifications of components / material to be used in motors.

Order Code Y50 in conjunction with M1Y can be used for coolant temp above 50°C & up to 60°C as standard operating range is -20 to 50°C.

Temperature class 180 (H)

Motor series 1LE7, temperature class 180 (H), utilized according to 155 (F) is permitted.

Order code **N10**

Temperature class 180 (H) at rated power and max. coolant temperature 60°C

Motor series 1LE7 can be ordered according to temperature class 180 (H) for utilization according to temperature class 155 (F) and a maximum coolant temperature of 60°C. Please enquire.

Order Code **Y75** can be used in conjunction with **M1Y** for coolant temp. above 50°C & up to 60°C as standard operating range is -20 to 50°C.

The grease lifetime specified is valid for a coolant temperature 50°C. If the coolant temperature is increased by 10 K, the grease lifetime and re-greasing interval are halved. (Refer page 9 for regreasing interval details)

Temperature class 155 (F), utilized acc. to 130 (B), with higher coolant temperature and/or installation altitude

The motors can be ordered according to temperature class 155 (F) for utilization according to temperature class 130 (B) with other customized requirements if they are specified in plain text in the order.

Order code **Y50** in conjunction with **M1Y**

Overview

Temperature class 180 (H), utilized according to 155 (F)

The motors can be ordered according to temperature class 180 (H) for utilization according to temperature class 155 (F) with other customized requirements if they are specified in plain text in the order.

Order code **Y75** in conjunction with **M1Y**

The specified rated power is applicable for continuous duty in accordance with IS 12615/ IEC 60034-1 at the frequency of 50 Hz, a coolant temperature (CT) or ambient temperature of 50°C and an installation altitude (IA) up to 1000 m above sea level. 1LE7 motors for ambient temperatures exceeding 50°C are equipped with various types of seal.

For higher coolant temperatures and/or installation altitudes greater than 1000 m above sea level, the specified motor power must be reduced using the factor k_{HT} .

Depending on the frame size of the motor or the number of poles, customized windings may be added to the motors for the different operating conditions.

This results in an admissible motor power of:

$$P_{adm} = P_{rated} \cdot k_{HT}$$

If the admissible motor power is no longer adequate for the drive, it should be checked whether the motor with the next higher rated power fulfills the requirements.

Abbreviation	Description	Unit
P_{adm}	Admissible motor power	kW
P_{rated}	Rated power	kW
k_{HT}	Factor for abnormal coolant temperature and/or installation altitude	

The motors are designed for temperature class 155 (F) and utilized in temperature class 130 (B). Under non-standard operating conditions, if they are to be used in this class, the admissible power rating must be determined from the table below.

Note for cases 60°C Ambient, please enquire.

k_{HT} Values

Installation altitude above sea level	Coolant temperature					
	< 30°C	30 ... 40°C	45°C	50°C	55°C	60°C
M						
1000	1.07	1.00	1.00	1.00	0.95	0.90
1500	1.04	0.97	0.97	0.97	0.92	0.87
2000	1.00	0.94	0.94	0.94	0.89	0.85
2500	0.96	0.90	0.90	0.90	0.86	0.81
3000	0.92	0.86	0.86	0.86	0.82	0.77
3500	0.88	0.82	0.82	0.82	0.78	0.74
4000	0.82	0.77	0.77	0.77	0.73	0.69

Coolant temperature and installation altitude are rounded to 5°C and 500m respectively.

For details of deration for utilization in temperature class 155 (F), see "DURIGNIT IR 2000 insulation system".

Ambient temperature:

All motors can be used in the standard version at ambient temperatures between -20 and +50°C. Exposure to direct sunlight can result in uncontrollable rise in motor temperature. Appropriate measures to prevent direct exposure to sunlight and rain shall be made by user.

Motors can be utilized to temperature class 155 (F).

At 50°C with service factor 1.15, i.e. the motor may be continuously overloaded with 15% of the rated power; however may exhibit a reduced lifetime in such a case. As a standard the motors are designed to conform to the efficiency requirement of the relevant efficiency class at the standard rated output.

Note: Should the motors be required to be continuously operated at SF load, IS 12615: 2018 requires that the motors meet the for a duration > 1h efficiency value corresponding to the SF power. In such case special designs are required to be offered and an enquiry should be made.

For other higher ambient temperatures (Up to 60°C) special measures are necessary, please enquire.

When brakes are to be mounted on motors intended for operation at temperatures below freezing, please enquire with nearest Sales office.

Anti-condensation heating

Supply voltage 230 V (1Ph AC)

Order code **Q02**

Supply voltage 115 V (1Ph AC)

Order code **Q03**

Supply voltage 240 V (1Ph AC)

Order code **Q07**

Supply voltage 120 V (1Ph AC)

Order code **Q08**

For motors with windings at risk of condensation due to the climatic conditions, e.g. inactive motors in humid atmospheres or motors that are subjected to widely fluctuating temperatures, anti-condensation heaters must be used.

Anti-condensation heaters can be offered from frame size 90 onwards.

An additional cable entry is provided for the connecting cable in the terminal box.

Frame size	Cable entry
90...180	1 x M16 x 1.5
200	1 x M20 x 1.5
225... 315	2 x M20 x 1.5

Anti-condensation heating must not be switched on during operation.

The blower motors finalized for 1LE7 range FS 160..315 are as follows :

S.No.	Main Motor FS/(Pole)	Blower motor FS / (Pole)	Series of blower	Supply	O/p (kW)	Current (A)	Eff. %	P.F.	Speed (rpm)	Eff. Class	Ambient	Marking & Logo
1	160 / (2.8P)	63 / (4P)	1PP0	240Δ/50Hz	0.12	0.64	64.8	0.70	1395	IE3	60°C	CE marked ISI logo
	180 / (2.8P)			415Y/50Hz	0.12	0.37	64.8	0.70	1395			
	200 / (2.8P)			265Δ/60Hz	0.14	0.64	66.0	0.72	1702			
	225 / (2.8P)			460Δ/60Hz	0.14	0.37	66.0	0.72	1702			
3	250 / (2.8P)	71 / (4P)	1LE7	240Δ/50Hz	0.37	1.7	78.0	0.67	1395	IE3	60°C	CE marked ISI logo
	280 / (2.8P)			415Y/50Hz	0.37	0.98	78.0	0.67	1395			
	315 / (2.8P)			265Δ/60Hz	0.43	1.7	78.2	0.69	1702			
				460Δ/60Hz	0.43	1	78.2	0.69	1702			

* Above data is subject to change based on testing / amendment in designs.

Frame size	Heating power of the anti-condensation heating Supply voltage at			
	230 V Order code Q02 W	115 V Order code Q03 W	240 V Order code Q07 W	120 V Order code Q08 W
1LE7 Motors				
90 ... 112	25	25	27	27
132 ... 200	55	55	60	60
225 ... 250	85	85	93	93
280 ... 315	107	107	117	117

Instead of an anti-condensation heater, for frame size up to 225 another possibility is to connect a voltage that is approximately 4 to 10 % of the rated motor voltage to stator terminals U1 and V1; 20 to 30 % of rated motor current is sufficient to heat the motor.

Fans/separately driven fans

All 1LE7 motors except those offered with options F70 or F90 are provided with shaft mounted fans which cool regardless of direction of rotation. These motors have a cooling method IC411 in accordance with IEC 60034-6. The air flow is from the NDE to DE. Please refer the table below to know more about the Material details for shaft mounted fans and fancowls.

Motor series	Frame size	Fan material	Fan cover material
1LE7	71 ... 315	Plastic	Sheet Metal

Notes:

- 1LE7... -Z, Z=F70 - This option stands for separately cooled motors - method of cooling IC416. These are provided in frames 160 - 315. Please refer below table for blower motor details: (screen shot of table is pasted below)
- 1LE7... -Z, Z=F90 - This option stands for motors without fan and fan-cowl, however cooled by the cooling air blown over the motor body by the fan these motors drive. This enclosure is also called TEAO - Totally Enclosed Air Over. The method of cooling is designated as IC418. These are provided in frames 71 - 315. The air flow required to be maintained in case of F90 (IC418) is indicated in the tables below.

Caution: Motors with F90 should not be coupled to any other equipment except an axial flow fan. Doing so will render the motors un-ventilated and thereby excessive overheating and significantly shortened life times.

1LE7 IE2 Flow (m ³ /min)				
Frame size	Pole			
	2	4	6	8
71	1.49	0.75	0.49	
80	1.82	0.90	0.60	
90	3.30	1.64	1.11	
100	3.80	2.10	1.50	
112		2.90	1.90	
132	6.30	6.30	4.60	
160	10.9	6.7	5	
180	12.4	14	5.2	
200	19.3	14.6	8	
225	22	26.7	15	
250	28	30	19	
280	47	33	24	
315	67	49	34	

* for Motor with 60Hz the flow needs to be increased by 20%

1LE7 IE3 Flow (m ³ /min)				
Frame size	Pole			
	2	4	6	8
71	1.49	0.75	0.36	0.42
80	1.36	0.66	0.42	0.3
90	2.86	1.34	0.87	0.65
100	3.80	2.10	1.50	1.2
112		2.20	1.70	1.6
132	6.30	4.60	3.10	2.4
160	10.9	6.7	5	6.7
180	11.6	7	5.2	7.0
200	13.7	7.6	8	5.9
225	17	15.0	18	22.4
250	19	15	16	20
280	26	28	23	24
315	40	33	34	43

* for Motor with 60Hz the flow needs to be increased by 20%.

Please enquire for flow rate for IE4 Motors.

For details of separately driven fans for frame size 160 to 315, see also "Separately driven fans" on page 10.

Supply voltage of separately driven fan for 1LE7 motors:

The supply voltage tolerance of the separately driven fan is ±10 %.

Metal Fan

The standard fan made of plastic can be replaced with a fan made of metal (cast Iron). This version is available for motor series 1LE7 (with the exception of 1LE7 with option **F90** – version "Motor without external fan and fan-cowl - IC418 - cooled by an airflow"). In case of separately cooled motor (IC416) please enquire with nearest sales office for metallic fan. A metal external fan is an optional feature available from Frame size 71 to 315

Order code **F76**

In confined spaces, it must be ensured that the minimum spacing is maintained between the fan cover and the wall and/or enclosure cover to prevent motor from over-heating due to reduced cooling-air flow.

- 1) For the frame size codes **A, D, F, H, J, K, L, N, T, U,** and **V** (in 14th digit of MLFB), a screwed-on cover (metal) is used in conjunction with the option **H03** (condensation drainage holes). Mounted separately driven fans or brakes are only available in sheet metal version.

Minimum Clearance from wall/fan grilles	
Frame size	mm
71	15
80, 90, 100	20
112	25
132	30
160	40
180, 200	90
225, 250	100
280, 315	110

Fan cover for textile industry

For 1LE7 motors (with the exception of 1LE7 with option **F90** – version "Forced-air cooled motors without external fan and fan cover") the standard version of the fan cover cannot be used in the textile industry.

For the motor series 1LE7 (with the exception of 1LE7 with option **F90** – version "Forced-air cooled motors without external fan and fan cover") a special version of the fan cover is available for the textile industry for frame size 80 to Frame size 160.

Order code **F75**

Motor Protection

The order variants for motor protection are coded with letters in the 15th position of the MLFB and, if necessary, using order codes.

In the standard version, the motor is designed without motor protection.

15th position of the MLFB letter **A**.

The following applies to all motors:

The motors can withstand 1.5 times the rated current at rated voltage and frequency for two minutes (IEC 60034-1/IS 15999 (Part 1))

Motor-temperature-dependent protective devices and motor temperature detection with converter operation

Depending on the specific requirements, various different components can be built into the motor winding for switching off the motor before it overheats and for monitoring the winding temperature and motor temperature.

Temperature detectors – Bimetal switches

Bimetal switches operate on the principle of mechanical deformation as a result of long-term heating. Bimetal strips bend as a result of such heating have a spring action that results in sudden reversal of the curvature (concave to convex or vice-versa).

When a limit temperature is reached, these temperature detectors (NC contacts) can deactivate an auxiliary circuit. The circuit can only be reclosed following a considerable fall in temperature. Bimetal switches are suitable protection devices in the case of slowly rising motor temperatures. When the motor current rises quickly (e.g. with a locked rotor), these switches are not suitable due to their large thermal time constants.

Temperature detectors for tripping: 15th position of the MLFB letter Z and order code Q3A & Q9A.

PTC thermistors – Thermistor motor protection

PTC thermistors provide the most comprehensive protection against thermal overloading of the motor. A rise in the winding temperature over the admissible value can be accurately detected thanks to the low heat capacity of these PTC (Positive Temperature Coefficient) thermistors and their excellent heat contact with the winding. When the limit temperature reaches rated tripping temperature, the PTC thermistors undergo a sudden change in resistance. This is evaluated by tripping units and can be used to open auxiliary circuits. PTC thermistors cannot themselves be subjected to high currents and voltages. This results in the destruction of the semiconductor. The switching hysteresis of the PTC thermistor and tripping unit is low, which supports fast restarting of the drive. Motor protection of this type is recommended for heavy duty starting, switching duty, extreme changes in load, high ambient temperatures or fluctuating supply systems.

Motor protection with PTC thermistor for tripping - in the terminal box, two auxiliary terminals are required.

In order to achieve full thermal protection, it is necessary to combine a thermally delayed over-current release and a PTC thermistor. For full motor protection to be implemented only with PTC thermistors, please inquire.

15th position of the MLFB letter **B**.

Two temperature sensor circuits are used if a warning is required before the motor is shut down (tripped). The warning is normally set to 10 K below the tripping temperature. Motor protection with PTC thermistor for alarm and tripping. In the terminal box, 4 auxiliary terminals are required.

15th position of the MLFB letter **C**.

PTC sensor characteristic

The PTC thermistor is a temperature-dependent component.

At the smallest changes in temperature in the region of the rated shutdown temperature, the resistance of the PTC increases steeply.

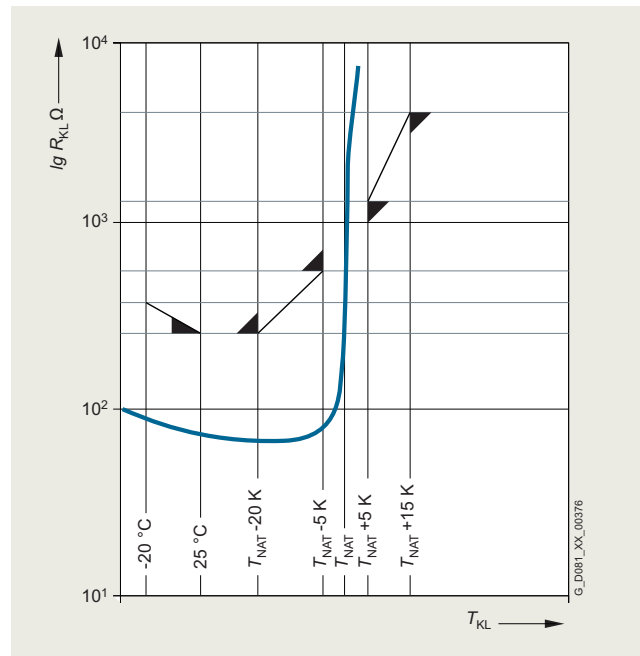

PTC sensor characteristic

Pt100/Pt1000 resistance thermometer

The resistance thermometer has a chip for a temperature sensor, the resistance of which changes in relation to temperature according to a series of reproducible basic values. The changes in resistance are transferred as changes in current. At 0°C, the measurement resistances are adjusted to 100 Ω for the Pt100 and 1000 Ω for the Pt1000, and correspond to the accuracy class B (i.e. the relationship between resistance and temperature). The limit deviation is ±0.3°C, and the admissible deviations are defined in EN 60751.

The Pt1000 resistance thermometer has replaced the KTY84-130 temperature sensors. Similar to the method of operation of the Pt100, the relationship between the temperature and the electrical resistance of conductors is utilized in the Pt1000 to measure the temperature, just like with the additional resistance thermometers described above. Pure metals undergo larger changes in resistance than alloys and have a relatively constant temperature coefficient.

The order options for the Pt100/Pt1000 temperature sensors are described in the option table. (15th position of the MLFB: **H, J, K, L**, or **Z** with order codes **Q1B, Q2B, Q65, Q2B+Q66**). Option codes **Q67, Q68** and **Q72** for Bearing temperature detection after -Z in MLFB.

Temperatures for alarm and tripping can be set as required when using converters from Siemens that determine the motor temperature in accordance with the measuring principle described above. With these devices, the measured signal is evaluated directly in the converter.

Pt100/Pt1000 resistance thermometer characteristics

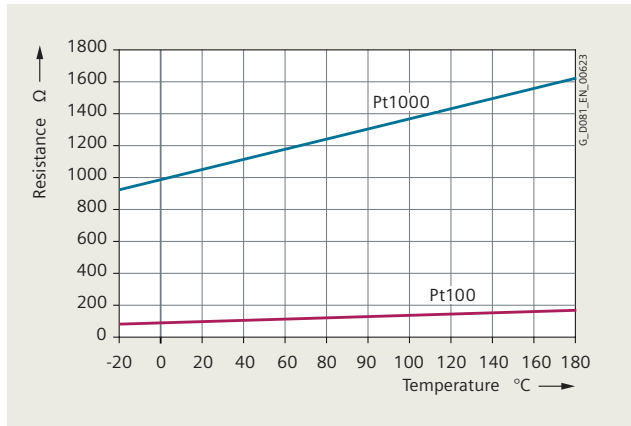

Location of the terminal box

The terminal box of the motor can be mounted in four different locations or positions. For 1LE7 motors, the standard terminal box position is on the top (16th position of the MLFB 4).

The position of the terminal box is coded using the 16th position of the motor MLFB

When defining the position of the terminal box, please observe the following:

- Motors with feet must always be viewed looking onto the drive end with the shaft in the horizontal position. The feet are then approx. 6 O'clock. This is especially important with construction types IM B6, IM B7, and IM B8, and also applies to combined construction types such as IM B35.
- Flange-mounted motors (e.g. IM B5) whose drive-end flange has a condensation drainage hole must always be viewed looking onto the drive end with the shaft in the horizontal position. The condensation drainage hole is then approx. 6 O'clock.

Terminal box on right-hand side:
16th position of the MLFB digit 5

Terminal box on left-hand side:
16th position of the MLFB digit 6

Terminal box below:
16th position of the MLFB digit 7

For Frame size 160 to 315 the LHS/RHS terminal box position is achieved by means of "L" shaped adaptor.

Location of the terminal box with the corresponding digits in the 16th position of the MLFB

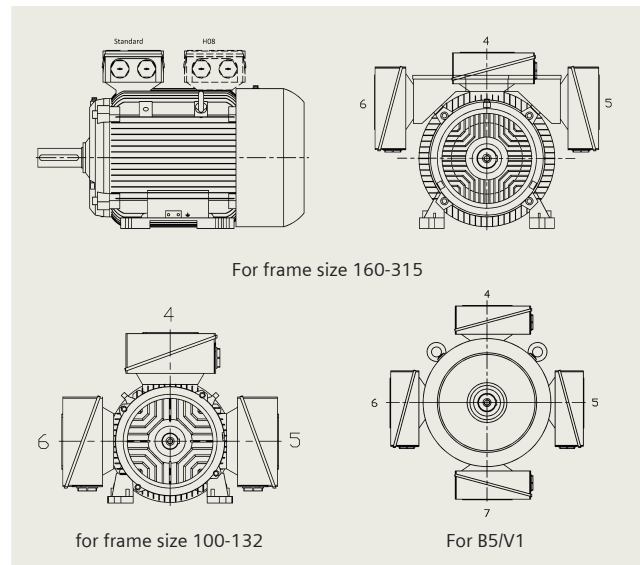

The number of winding ends depends on the winding design. Three-phase motors are connected to the three phase conductors L1, L2 and L3 of a three-phase system. The rated voltage of the motor in the running connection must match the phase conductor voltages of the network.

When the three phases are operating in a time sequence and are connected to the terminals of the motor in alphabetical order U1, V1 and W1, clockwise rotation of the motor shaft is established as viewed onto the drive end. The direction of rotation of the motor can be changed to counter-clockwise if two connecting leads are interchanged.

External grounding terminal/external grounding is standard for 1LE7 motors from frame size 71 upwards.

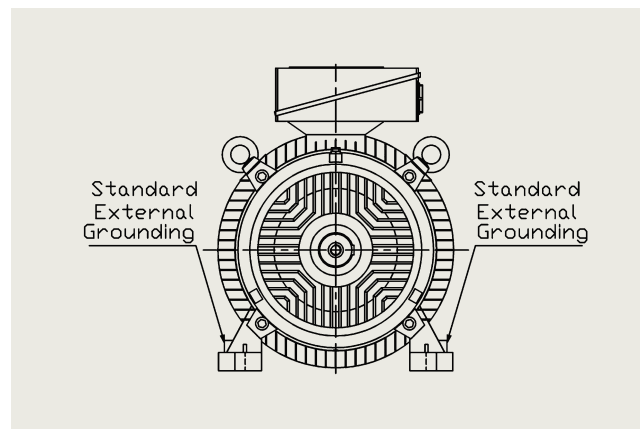

Design of the terminal box

The number of terminals and the size of the terminal box are designed for standard requirements.

For special requirements, or on customer request, a larger terminal box can be supplied for frame size 71 upwards.

Larger terminal box

Order code **R50**

If the necessary installation angle of the motor would cause machine components to collide with the terminal box, the terminal box can be moved from the drive end (DE) to the non-drive end (NDE). Only use according to temperature class 155 (F). When the terminal box is rotated to the non-drive end (NDE) of the motor, it is important to note that dimensions "C" and "CA" will not comply with the values specified by IS 1231. Dimensional drawings can be requested via Siemens Product Configurator (SPC).

Order code **H08**

Cable entry on terminal box

The terminal box can be rotated on the base of the motor housing such that the cable entry is located in the positions given below:

- Towards the drive end (DE)
(rotation of terminal box by 90°, entry from DE) for B5 types of constructions only with order code **H08**
With B14 construction types, the customer must ensure that sufficient space is available for cable outlet.
Order code **R10**
- Towards the fan end (NDE)
(rotation of terminal box by 90°, entry from NDE)
Order code **R11**
- Opposite the standard position 0°
(rotation of terminal box by 180°, entry opposite the standard position 0°)
Order code **R12**

The dimensions of the terminal box are listed in the section "Dimensions" on pages 47 to 62 in accordance with the frame size and the "Dimensional drawings".

If the position of the terminal box (right-hand side, left-hand side, or top) is changed, the position of the cable entry must be checked and, if necessary, ordered with the corresponding order codes (**R10**, **R11**, and **R12**).

Check SPC for providing R10, R11 and R12 along with auxiliary boxes.

Note: Preferred Position of Name Plate is RHS. However if the cable Entry is required from LHS, the Name plate shall be fixed on LHS



Terminal box in standard position, detailed view

Ordering example:

Terminal box on right-hand side (16th position of the MLFB digit 5):

Cable entry is from below unless another order code is specified.

Cable entry from drive end (DE) – MLFB with **-Z** and order code **R10**.

For cable entry to a standard terminal box, a metal cable gland can be ordered for motor connection.

One metal cable gland – MLFB with **-Z** and order code **R15**.

One size smaller cable entry can be ordered for motor connection
Order code **R30**.

Frame size	Cable entry	
	Std.	Reduced
100/112/132	2 × M32	2 × M25
160/180	2 × M40	2 × M32
200/225	2 × M50	2 × M40
250/280/315	2 × M63	2 × M50

Protruding cable ends

For confined spaces, protruding cable ends can be ordered without a terminal box with cover plate.

The following lengths of protruding cables can be ordered as standard using order codes:

- 6 cables protruding, 0.5 m long
Order code **R22**
- 6 cables protruding, 1.5 m long
Order code **R23**
- 6 cables protruding, 3.0 m long
Order code **R24**

The cross-section of the named cable refers to a coolant temperature of up to 50°C.

Technical specifications for terminal boxes for 1LE7 motors

Frame size	Terminal box Standard/larger (order code R50)	Number of terminals	Thread of the contact screw	Max. connectable cable mm ²	Outer cable diameter (sealing range) mm	Cable entry
1LE7						
71 ... 90	TB17D04/TB1E14	6	M4	6 with cable lug	M16 × 1.5: 4.5 ... 10 M25 × 1.5: 9 ... 17	1 × M16 × 1.5 + 1 × M25 × 1.5
100 112	TB7F04/TB1F14	6	M5	6/10	11 ... 21	2 × M32 × 1.5
132	TB1H04/TB1H14	6	M5	6/10	11 ... 21	2 × M32 × 1.5
160	TB1J04/TB1K01	6	M5	25	19 ... 28	2 × M40 × 1.5
180	TB1J04/TB1K01	6	M5/M6	25/35	19 ... 28/ 27 ... 35	2 × M40 × 1.5/ 2 × M50 × 1.5
200	TB1L01/TB1L01	6	M6/M8	35	27 ... 35	2 × M50 × 1.5 / 2 × M50 × 1.5
225	TB1L01/TB1N01	6	M8/M10	35/120	27 ... 35/ 34 ... 42	2 × M50 × 1.5/ 2 × M63 × 1.5
250	TB1N01/TB1Q01	6	M10/M12	120/185	34...42/ 38 ...45	2 × M63 × 1.5 / 2 × M63 × 1.5
280	TB1N01/TB1Q01	6	M10/M12	120/185	34...42/ 38 ...45	2 × M63 × 1.5 / 2 × M63 × 1.5
315	TB1Q01/TB1R01	6	M12/M16	185/300	38 ... 45/ 56 ... 68.5	2 × M63 × 1.5/ 2 × M80 × 2

Note: Thread sizes Cable Entry other than mentioned above can be ordered with order code **Y61**. Please enquire.

- 1) Aluminium terminal box from frame size 71 to 132 as a standard.
 CR Steel terminal Box for frame size 160 to 180 as a standard
 (after 1st December 22). CI terminal box is offered as a standard for
 frame size 200 to 315. All other terminal boxes are cast-iron boxes.
 Cast iron terminal box can be offered with option R64 where Al.
 Terminal boxes are standard, as per below table

Aluminium TB	Cast Iron TB
TB7D04	TB7D01
TB1E14	TB1D11
TB7F04	TB7F01
TB1F14	TB1J01
TB1H04	TB1H01
TB1H14	TB1J01
TB1J04	TB1J01

Auxilliary boxes can be offered only with cast iron terminal box.

- 2) Designed for cable glands with O-ring.

There are two types of auxiliary terminal boxes R62 (TB2J01) and R63 (TB2N01). These auxiliary boxes get automatically selected based on number of auxiliary leads required. Please refer to SPC.

TB2J01-R62

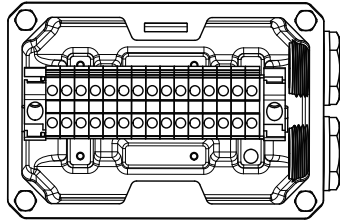

TB2N01-R63

TB2N01 (R63)

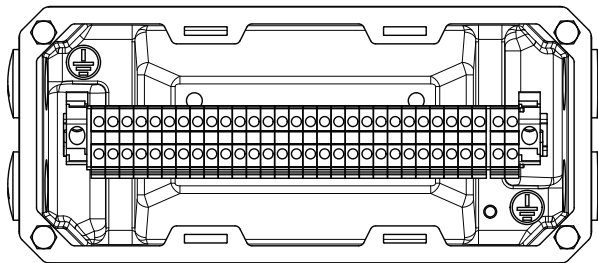

All motors are designed to degree of protection IP55. They can be installed in dusty or humid environments. The motors are suitable for operation in tropical climates.

Brief explanation of the degree of protection

IP55:

- Protection against harmful dust deposits
- Protection against water jets from any direction

IP56:

- Protection against harmful dust deposits
- Protection against powerful water jets from any direction

Order code **H22**

Important: Note that submersion by waves or total immersion, even temporarily, is not permitted especially in the case of motors with fans. This corresponds to IP67 or IP68 degree of protection. Degree of protection IPX7 and IPX8 is currently not available.

IS/IEC 60034-5 defines protection level 6 for water protection as: "Protection against water due to heavy seas or water in a powerful jet". IP56 degree of protection can only be used with the requirement "Protection against a powerful jet" and not for the requirement "Protection against heavy sea".

IP65:

- Complete protection against dust deposits
- Protection against water jets from any direction

Order code **H20**

IS/IEC 60034-5, the code 6 for protection against the ingress of foreign bodies and touch hazard protection for electrical machines.

With motors that have a vertical shaft extension, the end user must prevent an ingress of fluid along the shaft.

For motors with shaft extension pointing downwards, the version "Protective cover for types of construction" order code **H00** is highly recommended, see also the explanations on "Types of construction" on page Standard types of construction and special types of construction.















With flange-mounted motors, for IM V3 type of construction, collection of fluid in the flange basin can be prevented by drainage holes (on request).

The condensation drainage holes at the drive end (DE) and non-drive end (NDE) are sealed (IP55) on delivery. If the condensation drainage holes are ordered for motors of the IM B6, IM B7 or IM B8 type of construction (feet on side or top), the position of the drainage holes will be in the correct position for the type of construction.

Order code **H03**

For motors with IP56 / IP65 enclosure - Brake continues to be with degree of protection IP55.





Standard types of construction and special types of construction

Type of construction acc. to IS 2253/ IEC 60034-7		Frame size	Letter of the 14th position of the MLFB	Additional identification code -Z with order code
Without flange				
IM B3/IM 1001		71 to 315L	A	-
IM B6/IM 1051 ¹⁾		71 to 315L	T	-
IM B7/IM 1061 ¹⁾		71 to 315L	U	-
IM B8/IM 1071 ¹⁾		71 to 315L	V	-
IM V5/IM1011 ¹⁾ without protective cover		71 to 315L	C	-
IM V6/IM 1031 ¹⁾		71 to 315L	D	-
IM V5/IM 1011 ¹⁾³⁾ with protective cover		71 to 315L	C	+ H00 ²⁾
With flange				
IM B5/IM 3001		71 to 315M	F	-
IM V1/IM 3011 without protective cover		71 to 315L	G	-
IM V1/IM 3011 ³⁾ with protective cover		71 to 315L	G	+ H00 ²⁾
IM V3/IM 3031		71 to 315M	H	-
IM B35/IM 2001		71 to 315L	J	-
IM V15/IM 2011		71 to 315L	W	-
IM V36/IM 2001		71 to 315L	Y	-

1) For installation of foot mounting motors on a wall, support should be provided for the mounting feet

2) In the case of all types of construction with shaft extension pointing downwards, the version "with protective cover" is highly recommended.

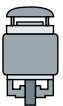
3) Standard Double shaft extension (second shaft extension) L05, Y59 and Y63 is not possible.

Type of construction acc. to IEC 60034-7/ IS 2253		Frame size	Letter of the 14th position of the MLFB	Additional identification code –Z with order code
With flange				
IM B14/IM 3601		71 to 132M	K	–
IM V19/IM 3631		71 to 132M	L	–
IM V18/IM 3611 without protective cover		71 to 132M	M	–
IM V18/IM 3611 ²⁾ with protective cover		71 to 132M	M	+ H00 ²⁾
IM B34/IM 2101		71 to 132M	N	–

The dimensions of the following types of construction are identical:

IM B3, IM B6, IM B7, IM B8, IM V5 and IM V6
 IM B5, IM V1 and IM V3
 IM B14, IM V18 and IM V19

Motors in the standard power range can be ordered in basic types of construction

IM B3 and can be operated in mounting positions IM B6*, IM B7*, IM B8*, IM V5*, IM V6*

IM B5 and operated in mounting positions IM V1, IM V3

IM B14 and operated in mounting positions (up to frame size 132) IM V18 and IM V19

Lifting eyes are available for transport and installation in a horizontal position. In conjunction with the lifting eyes, for the purpose of stabilizing the position when the motor is arranged vertically, additional slings (EN 1492-1) and/or lashings (EN 12195-2) must be used. Eye bolt is to be used for lifting Motor only. Not to be used for Lifting along with other foundation auxiliaries and installation in a horizontal position.

In conjunction with the lifting hooks/eye bolts, for the purpose of stabilizing the position when the motor is arranged vertically, additional appropriate lifting straps and/or clamping bands must be used.

The motors are designated in accordance with the types of construction on the rating plate.

With motors that have a vertical shaft extension, the end user must prevent an ingress of fluid along the shaft.

- 1) For installation of foot mounting motors on a wall, support should be provided for the mounting feet
- 2) In the case of all types of construction with shaft extension pointing downwards, the version "with protective cover" is highly recommended.

- 3) Standard Double shaft extension (second shaft extension) **L05, Y59** and **Y63** is not possible.

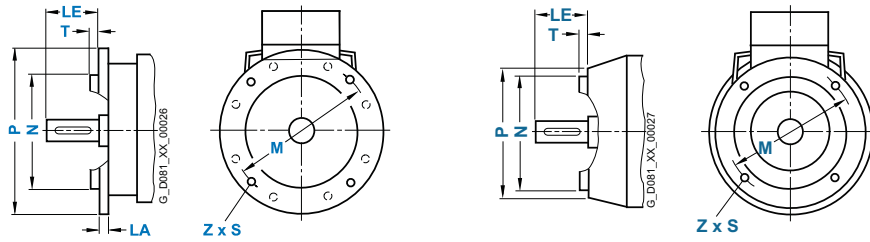

In IS 2223, the frame sizes are allocated "B" type flange with through holes and "C" type flange with tapped holes.

Frame size	Type of construction	Flange type	Flange with through holes ("B" type) Flange with tapped holes ("C" type) Acc. to IS 2223	Dimension designation acc. to IEC							
				LA	LE	M	N	P	S	T	Z
71	IM B5, IM B35, IM V1, IM V3	Flange	F 130 B	9	30	130	110	160	10	3.5	4
	IM B14, IM B34, IM V18, IM V19	Flange	F 85 C	–	30	85	70	105	M6	2.5	4
80	IM B5, IM B35, IM V1, IM V3	Flange	F 165 B	10	40	165	130	200	12	3.5	4
	IM B14, IM B34, IM V18, IM V19	Flange	F 100 C	–	40	100	80	120	M6	3	4
90 S/L	IM B5, IM B35, IM V1, IM V3	Flange	F 165 B	10	50	165	130	200	12	3.5	4
	IM B14, IM B34, IM V18, IM V19	Flange	F 115 C	–	50	115	95	140	M8	3	4
100 L	IM B5, IM B35, IM V1, IM V3	Flange	F 215 B	11	60	215	180	250	15	4	4
	IM B14, IM B34, IM V18, IM V19	Flange	F 130 C	–	60	130	110	160	M8	3.5	4
112 M	IM B5, IM B35, IM V1, IM V3	Flange	F 215 B	11	60	215	180	250	15	4	4
	IM B14, IM B34, IM V18, IM V19	Flange	F 130 C	–	60	130	110	160	M8	3.5	4
132 S/M	IM B5, IM B35, IM V1, IM V3	Flange	F 265 B	12	80	265	230	300	15	4	4
	IM B14, IM B34, IM V18, IM V19	Flange	F 165 C	–	80	165	130	200	M10	3.5	4
160 M/L	IM B5, IM B35, IM V1, IM V3	Flange	F 300 B	13	110	300	250	350	19	5	4
180 M/L	IM B5, IM B35, IM V1, IM V3	Flange	F 300 B	13	110	300	250	350	19	5	4
200 L	IM B5, IM B35, IM V1, IM V3	Flange	F 350 B	15	110	350	300	400	19	5	4
225 S/M 2-pole 4- ... 8-pole	IM B5, IM B35, IM V1, IM V3	Flange	F 400 B	16	110 140	400	350	450	19	5	8
250 M	IM B5, IM B35, IM V1, IM V3	Flange	F 500 B	18	140	500	450	550	19	5	8
280 S/M	IM B5, IM B35, IM V1, IM V3	Flange	F 500 B	18	140	500	450	550	19	5	8
315 S/M/L 2-pole 4- ... 8-pole	IM B5, IM B35, IM V1, IM V3	Flange	F 600 B	22	140 170	600	550	660	24	6	8

Mounting construction IM B5 is not available in 315L.

*Validity of Construction please refer pg 39

Shaft Extension

60° center hole acc. to DIN 332, Part 2 with M3 to M24 tapped hole depending on the shaft diameter.

DE (shaft extension)	
Diameter mm	Thread mm
7 ... 10	DR M3
> 10 ... 13	DR M4
> 13 ... 16	DR M5
> 16 ... 21	DR M6
> 21 ... 24	DR M8
> 24 ... 30	DR M10
> 30 ... 38	DR M12
> 38 ... 50	DR M16/DS M16
> 50 ... 85	DS M20
> 85 ... 130	DS M24

Shaft made of stainless steel

A shaft made of stainless steel X20Cr13 (IS 6603) can be ordered for the 1LE7 motor series.

Order code **L06**

Non-standard cylindrical shaft extension

The non-standard cylindrical shaft extension can be used on the drive end (DE) (with plain text).

Order code **Y58**. Please enquire

Please also enquire about the transmitted power and admissible cantilever force if belt pulleys, chains or gear pinions are used on the standard, cylindrical shaft extension.

A standard, cylindrical shaft extension (second shaft extension) NDE is not available if a rotary pulse encoder and/or a separately driven fan has been mounted onto the motor. Please enquire for mounted brakes.

Dimensions and tolerances for keyways and keys are designed in accordance with IS : 2048. The motors are always supplied with a key inserted in the shaft. Unless customer has specifies any other requirements.

All other dimensions are available on request. Please enquire.

It is the responsibility of the customer to ensure that the admissible cantilever forces are reduced in accordance with the non-standard shaft extension.

In case of belt pull forces or any transverse load on the shaft, please confirm the shaft and bearing suitability by enquiry.

Concentricity of shaft extension, co-axiality, and linear movement in accordance with IEC 60072-1 Tolerance R for flange-mounted motors

The following are specified in DIN 42955 with Tolerance N (normal) and Tolerance R (reduced):

1. Concentricity tolerances for the shaft extension
2. Co-axiality tolerances for the shaft extension and flange centering
3. Linear movement tolerances for the shaft extension and flange surface

The concentricity of the shaft extension, co-axiality and linear movement according to IEC 60072-1 Tolerance R for flange-mounted motors can be ordered using order code **L08**.

This order code can be combined for motors with deep-groove bearings of series 62.. and 63... This is not possible in combination with a mounted brake or encoder.

Concentricity of the shaft extension can be ordered according to IEC 60072-1 Tolerance R for types of construction without flange with order code **L07**.

Concentricity tolerance for the shaft extension

Diameter of the cylindrical shaft extension D mm	Concentricity tolerance	
	N (normal) mm	R (reduced) mm
≤ 10	0.03	0.015
> 10 ... 18	0.035	0.018
> 18 ... 30	0.04	0.021
> 30 ... 50	0.05	0.025
> 50 ... 80	0.06	0.03
> 80 ... 120	0.07	0.035
> 120 ... 180	0.08	0.04
> 180 ... 250	0.09	0.045
> 250 ... 315	0.1	0.05
> 315 ... 400	0.11	0.055
> 400 ... 500	0.125	0.063
> 500 ... 600	0.14	0.07
IEC dimension code D		

Co-axiality tolerance of the centering spigot and linear movement tolerance of the flange surface to the shaft extension axis

Mounting flange Centering diameter N mm	Co-axiality tolerance and linear movement tolerance	
	N (normal) mm	R (reduced) mm
≤ 22	0.05	0.025
> 22 ... < 40	0.06	0.03
40 ... 100	0.08	0.04
> 100 ... 230	0.1	0.05
> 230 ... 450	0.125	0.063
> 450 ... 800	0.16	0.08
> 800 ... 1400	0.2	0.1
> 1400 ... 2000	0.25	0.125
> 2000 ... 2240	0.315	0.16
IEC dimension code N		

The flange-mounted motors can be equipped with a radial sealing ring in order to mount on gear box.

Order code **H23**

It must be ensured that the sealing ring is lubricated using grease, oil mist, or oil spray. (It is not admissible to use pressurized oil > 0.1 bar.) We recommend that the admissible bearing loads are carefully checked.

All rotors are dynamically balanced with an inserted half key. This corresponds to vibration severity grade A (normal or standard). IS/IEC 60034-14 regulates the vibrational behavior of machinery. Based on ISO 8821, the key convention "half key (H)" must be used for balancing.

Note:

If there is a keyway, a full feather key is always inserted on delivery.

The type of key convention is stamped on the nameplate:

F = Balancing with full key
(full-key convention)

H = Balancing with half key
(half-key convention) – standard

N = Balancing without key –
Plain text required (convention without key)

Full-key balancing or balancing with full feather key (F) is possible by specifying order code **L02**.

Balancing without feather key (N) is possible by specifying order code **L01**

Vibration severity grade A is the standard version and is valid up to a rated frequency of 60 Hz.

The low-vibration version B can be supplied to fulfill stricter requirements on smooth running (additional charge).

Order code **L00**

For details, see standard IS/IEC 60034-14

Noise Level for Line Operation

The noise is measured in a noise proof chamber. It is specified as A-weighted enveloping surface sound pressure level L_{pFA} in dB (A).

This value is the spatial average value of the sound pressure levels measured at the measuring surface. The measuring surface is a cube 1 m away from the surface of the motor. The sound power level is also specified as L_{WA} in dB (A).

The specified values are valid at 50 Hz and rated power (see the selection and ordering data). The tolerance is +3 dB.

Bearing lifetime (nominal lifetime)

The nominal bearing lifetime is defined according to standardized calculation procedures (ISO 281) and is reached or even exceeded for 90 % of the bearings when the motors are operated in compliance with the data provided in the catalogue.

Under average operating conditions, a lifetime (L_{10h}) of 50,000 hours can be achieved.

Generally, the bearing lifetime is defined by the bearing size, the bearing load, the operating conditions, the speed and the grease lifetime. A bearing lifetime calculation is possible on request.

Bearing system

The bearing lifetime of motors with horizontal mounting is 50,000 hours if there is no additional axial loading and radial forces at the coupling output and 20,000 hours when utilized according to the maximum admissible load. This assumes that the motor is operated at 50 Hz. The nominal bearing lifetime is reduced for converter operation at higher frequencies.

In order to achieve the calculated lifetime in continuous operation, the admissible vibration values (measured at bearing plate) must be determined according to evaluation zones A and B-stipulated in ISO 10816. If higher vibration velocities occur in operation (e.g. with option **H02**), special measures must be taken (please enquire).

Due to their physical characteristics, variable-speed motors have a different bearing lifetime under the same load conditions – this relationship is linear, i.e. if the frequency increases by 20 % from 50 Hz to 60 Hz, the lifetime decreases by 20 % from 20,000 to 16,000 hours under the load conditions specified in the catalogue. Refer Cantilever Forces Sheet pg. 25.

If the frequency falls by 20 % from 50 Hz to 40 Hz, under the load conditions specified in the catalogue, the lifetime rises by 20 % from 20,000 to 24,000 hours. Refer Cantilever Forces Sheet pg. 25.

In the basic bearing system, the floating bearing is situated at the drive end (DE) and the located bearing is situated at the non-drive end (NDE).

The DE Bearing can be fixed and NDE Can be made Floating. Order Code **L20**.

The bearing system is axially preloaded with a spring element at the drive end (DE) to ensure smooth running of the motor without play (see Fig. 1 in the diagrams of bearings on page Diagrams of bearings).

For increased cantilever forces (e.g. belt drives), reinforced bearings can be used at the drive end (DE) for frames 160 to 315.

Order code **L22**

1LE7 motors in frame sizes 71 to 132, can be supplied with reinforced bearings (size range 03) at both ends.

Order code **L25**

A measuring nipple for SPM shock pulse measurement can be mounted to check bearing vibration. The motors have an M8 tapped hole for each bearing plate and a measuring nipple with a protective cap. If a second tapped hole is provided, it is fitted with a sealing cap. Not possible for frame sizes < 160.

Order code **Q01**

Permanent lubrication

On motors equipped with permanent lubrication, the bearing grease lifetime is matched to the bearing lifetime. This can, however, only be achieved if the motor is operated in accordance with the catalogue specifications.

The motors from frame size 71 to 200 are provided with bearings having permanent lubrication.

The motors from frame size 225 to 315 can also be provided with bearings having permanent lubrication. (For Ball-Ball bearing only and Not for insulated bearing)

Order Code: **L33**

Regreasing

Regreasing is a standard feature for frame size 225 and upwards.

Frame sizes 225 to 315: M10 x 1 acc. to DIN 3404-A (flat lubricating nipple).

In the case of motors with regreasing, information regarding regreasing intervals, quantity of grease, type of grease and any additional data is provided on the lubrication plate or rating plate.

Mechanical stress and grease lifetime

High speeds that exceed the rated speed with converter operation and the resulting increased vibrations alter the mechanical running smoothness and the bearings are subjected to increased mechanical stress. This reduces the grease lifetime and the bearing lifetime (please enquire where applicable).

The use of rigid couplings should be avoided as far as possible.

For converter operation in particular, compliance with the mechanical limit speeds n_{max} is essential, see the following table "Mechanical limit speeds n_{max} ".

Mechanical limit speeds n_{max} for 1LE7 motors with standard bearing configuration –

Frame size	Type	2-pole	4-pole	6-pole	8-pole
		n_{max} rpm	n_{max} rpm	n_{max} rpm	n_{max} rpm
1LE7..					
71 M	0C...	6000	4200	3600	3000
80 M	0D...	6000	4200	3600	3000
90 S/L	0E...	6000	4200	3600	3000
100 L	1A...	6000	4200	3600	3000
112 M	1B...	6000	4200	3600	3000
132 S/M	1C...	5600	4200	3600	3000
160 M/L	1D...	4800	3600	3000	2400
180 M/L	1E...	4800	4200	4200	4200
200 L	2A...	4800	4800	4800	4800
225 S/M	2B...	4500	4500	4400	4400
250 M	2C...	3900	3700	3700	3700
280 S/M	2D...	3600	3000	3000	3000
315 S/M/L	3A...	3600	2600	2600	2600

The specified limit speeds are applicable to motors without additional mountings, such as brakes or rotary encoders. In such applications, the characteristics of the respective mounting parts must be taken into account.

Grease lifetime and regreasing intervals for horizontal installation

Motor series	Frame size	No. of poles	Grease lifetime up to CT 50°C ²⁾	
Permanent lubrication¹⁾				
1LE7	71 ... 200	2 ... 8	20000 h or 50000 h ³⁾	
Regreasing¹⁾				
1LE7	100 ... 160	2 ... 8	Lubrication interval Insulation Class F 155°C	
			CT ≤ 60°C	60°C < CT ≤ 80°C
	180 ... 280	2	8000	4000
			4 ... 8	8000
	315	2	3000	1500
			4 ... 8	6000

1) For special uses and special greases, please enquire about grease lifetime and regreasing intervals.

2) For every 10 K the coolant temperature is increased above 80°C, the grease lifetime and regreasing interval are halved

3) 50000 hours apply to horizontally installed motors with coupling output without additional axial loads.

4) Re greasing facility is available for Frame size 100 to 200 with option code L23. Lubrication interval is applicable for L23 Option Motors.

Bearing assignment for 1LE7 motors

Frame size	No. of poles	Drive end (DE) bearing Horizontal and vertical type of construction	Non-drive end (NDE) bearing Horizontal and vertical type of construction	Fig. No. on page Diagrams of bearings
1LE7				
71	2 ... 8	6202 2ZC3	6202 2ZC3	Fig. 1
80	2 ... 8	6204 2ZC3	6204 2ZC3	Fig. 1
90 S/L	2 ... 8	6205 2ZC3	6204 2ZC3	Fig. 1
100 L	2 ... 8	6206 2ZC3	6206 2ZC3	Fig. 1
112 M	2 ... 8	6206 2ZC3	6206 2ZC3	
132 S/M	2 ... 8	6208 2ZC3	6208 2ZC3	
160 M/L	2 ... 8	6309 2ZC3	6309 2ZC3	Fig. 4
180 M/L	2 ... 8	6310 2ZC3	6310 2ZC3	Fig. 4
200 L	2 ... 8	6312 2ZC3	6312 2ZC3	
225 S/M	2 ... 8	6313 C3	6313 C3	
250 M	2 ... 8	6315 C3	6315 C3	
280 S/M	2	6315 C3	6315 C3	Fig. 2
	4 ... 8	6317 C3	6317 C3	
315 S/M/L	2	6316 C3	6316 C3	
	4 ... 8	6319 C3	6319 C3	

Bearing selection table for 1LE7 motors (bearings reinforced at both ends – order code L25)

Frame size	No. of poles	Drive end (DE) bearing Horizontal and vertical type of construction	Non-drive end (NDE) bearing Horizontal and vertical type of construction	Fig. No. on page Diagrams of bearings
1LE7				
71	2 ... 8	6302 2ZC3	6302 2ZC3	Fig. 1
80	2 ... 8	6304 2ZC3	6304 2ZC3	
90 S/L	2 ... 8	6305 2ZC3	6304 2ZC3	
100 L	2 ... 8	6306 2ZC3	6306 2ZC3	
112 M	2 ... 8	6306 2ZC3	6306 2ZC3	
132 M	2 ... 8	6308 2ZC3	6308 2ZC3	

Bearing selection table for 1LE7 motors (bearings for increased cantilever forces – order code L22)

For NU bearings (cylindrical roller bearings), in contrast to ball bearings, a minimum cantilever force is required.

Cylindrical roller bearings are not suitable for coupling output.

$$F_{\min} \sim F_{\max} / 2$$

Frame size	No. of poles	Drive end (DE) bearing Horizontal and vertical type of construction	Non-drive end (NDE) bearing Horizontal and vertical type of construction	Fig. No. on page Diagrams of bearings
1LE7				
160 M/L	2 ... 8	NU 309	6309 C3	Fig. 3
180 M/L	2 ... 8	NU 310	6310 C3	
200 L	2 ... 8	NU 312	6312 C3	
225 M	2 ... 8	NU 313	6313 C3	
250 M	2 ... 8	NU 315	6315 C3	
280 M	2	NU 315	6315 C3	
	4 ... 8	NU 317	6317 C3	
315 M/L	2	NU 316	6316 C3	
	4 ... 8	NU 319	6319 C3	

Diagrams of bearings

Fig. 1 Drive-end bearing (ZZ Ball Bearing)

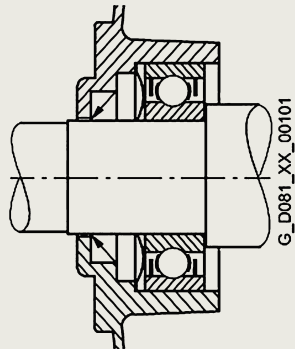

Non-drive end bearing (ZZ Ball Bearing)

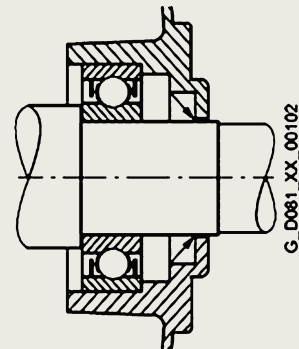
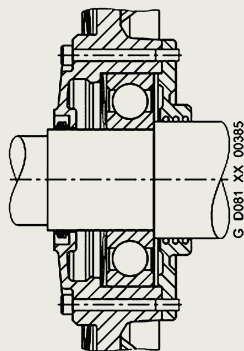

Fig. 2 Drive-end bearing (Re-greaseable Ball Bearing)



Non-drive end bearing (Re-greaseable Ball Bearing)

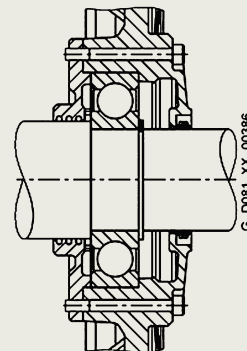
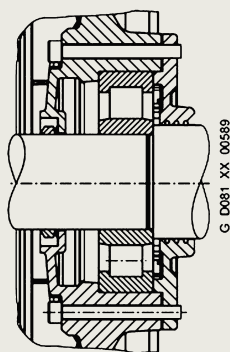

Fig. 3 Drive-end bearing (NU Bearing)



Non-drive end bearing (Re-greaseable Ball Bearing)

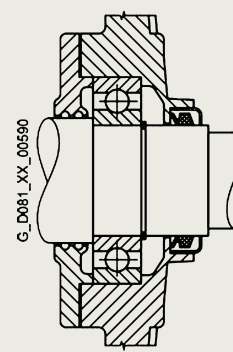
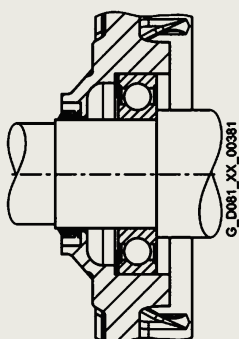
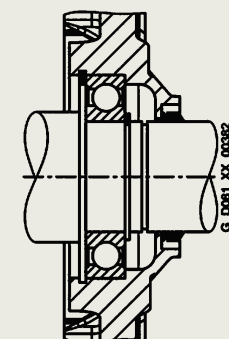

Fig. 4 Drive-end bearing (ZZ Ball Bearing)



Non-drive end bearing (ZZ Ball Bearing)



Admissible cantilever forces

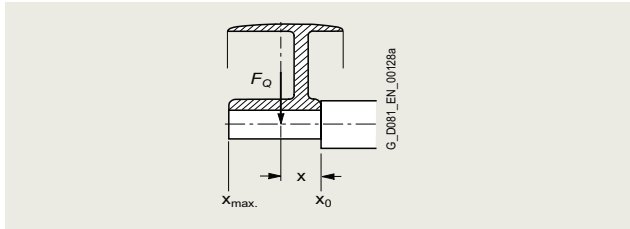

In order to calculate the admissible cantilever forces for a radial load, the line of force (i.e. the centerline of the pulley) of the cantilever force F_Q (N) must be within the free shaft extension (dimension x).

Dimension x (mm) is the distance between the point of application of the force F_Q and the shaft shoulder. The dimension x_{max} corresponds to the length of the shaft extension.

Total cantilever force $F_Q = c \cdot F_u$

The pre-tension factor c is a value gained from experience from the belt manufacturer. The following approximate value can be assumed:

For normal flat leather belts with an idler pulley $c = 2$;
 for V-belts $c = 2$ to 2.5 ;
 for special synthetic belts (depending on the type of load and type of belt) $c = 2$ to 2.5 .

The circumferential force F_u (N) is calculated using the following equation

$$F_u = 2 \cdot 10^7 \frac{P}{n \cdot D}$$

- F_u circumferential force in N
- P rated motor power (transmitted power) in kW
- n rated motor speed in rpm
- D belt pulley diameter in mm

Admissible cantilever forces – basic version

1LE7 motors at 50 Hz			
Valid are: x_0 values for $x = 0$ and x_{max} values for $x = l$ (l = shaft extension) only for 20,000hrs			
Frame size	No. of poles	Admissible cantilever force	
		at x_0	at x_{max}
		N	N
1LE7			
71	2	390	325
71	4	470	395
71	6	545	435
80	2	665	550
80	4	810	690
80	6	930	795
90	2	710	585
90	4	895	740
90	6	995	840
100	2	995	815
100	4	1080	880
100	6	1400	1120
112	4	1205	975
112	6	1395	1130
132	2	1290	1025
132	4	1825	1460
132	6	2095	1665
160	2	2460	1905
160	4	3035	2420
160	6	3940	3100
180	2	2860	2295
180	4	3615	2875
180	6	4150	3290
200	2	3800	3120
200	4	4820	3960
200	6	6220	5100
225	2	4400	3650
225	4	6110	4875
225	6	7040	5615
250	2	5280	4220
250	4	7515	6050
250	6	8560	6885
250	8	9500	7670
280	2	5200	3695
280	4	8140	6650
280	6	9325	7620
280	8	10300	8415
315(S/M)	2	4660	3960
315(S/M)	4	8765	7035
315(S/M)	6	10515	8435
315(S/M)	8	10205	8445
315(L)	2	4310	3780
315(L)	4	8350	7150
315(L)	6	9970	6160
315(L)	8	11100	4330

In the case of cantilever forces that exceed this, see "Bearings for increased cantilever forces". For IE4 Motors, please enquire.

Admissible cantilever forces – with reinforced deep groove ball bearings for increased cantilever forces – order code L25

1LE7 motors at 50 Hz			
Valid are: x_0 values for $x = 0$ and x_{max} values for $x = l$ (l = shaft extension) for 20000			
For motors		Admissible cantilever force	
Frame size	No. of poles	at x_0 N	at x_{max} N
1LE7501/03 – Basic Line			
71	2	605	445
71	4	740	425
71	6	860	420
80	2	855	710
80	4	1050	825
80	6	1210	830
90	2	1100	905
90	4	1395	1145
90	6	1565	1300
100	2	1435	1180
100	4	1790	1470
100	6	2030	1625
112	4	1760	1425
112	6	2030	1645
132	2	2260	1755
132	4	2700	2170
132	6	3100	2435
160	2	4905	2895
160	4	6120	2695
160	6	6870	2625
180	2	6225	3560
180	4	7825	3560
180	6	8620	3560
200	2	8570	5280
200	4	10780	5280
200	6	11965	5280
225	2	10340	7390
225	4	12730	6660
225	6	14620	6660
250	2	13635	7605
250	4	16990	9065
250	6	19400	8965
250	8	21000	8845
280	2	13325	9390
280	4	18735	13575
280	6	21455	14065
280	8	23650	14290
315(S/M)	2	13920	6685
315(S/M)	4	22720	12800
315(S/M)	6	26485	12850
315(S/M)	8	29635	11625
315(L)	2	13740	6685
315(L)	4	22885	8375
315(L)	6	26345	6160
315(L)	8	29210	4330

Please enquire should the information is required for IE4 Motors.

Note:

1. above specified values are for Horizontal Motors only.
2. Above Specified Load are for Cases with radial force only, in case of Axial Force please enquire.

Admissible cantilever forces – with cylindrical roller bearings at DE for increased cantilever forces – order code L22

1LE7 motors at 50 Hz with reinforced deep-groove bearings at DE up to frame size 132 with cylindrical roller bearings at DE in frame size 160 and above			
Valid are: x_0 values for $x = 0$ and x_{max} values for $x = l$ (l = shaft extension)			
For motors		Admissible cantilever force	
Frame size	No. of poles	at x_0 N	at x_{max} N
1LE7501/03 – Basic Line			
160	2	6200	3000
	4	7630	2890
	6	8370	2850
180	2	6470	4560
	4	7960	4340
	6	8900	4330
200	2	9100	6850
	4	11160	6630
	6	12500	6550
225	2	11070	6780
	4	13350	6620
	6	15100	6620
250	2	16020	6900
	4	19500	8500
	6	22020	8450
	8	24230	8350
280	2	15740	8650
	4	23530	13000
	6	26330	13150
	8	28770	13000
315 S/M	2	16670	7850
	4	27010	11700
	6	29810	11500
	8	33430	11000
315 L	2	16450	7100
	4	26370	10250
	6	30300	10300
	8	32790	9250

Please enquire should the information is required for IE4 Motors.

When the motors are used or stored outdoors, we recommend that they be kept under some sort of additional cover so that they are not subjected to direct intensive solar radiation, rain, snow, ice or dust over a long period of time. In such cases, technical consultation may be appropriate.

When the motors are used outdoors or in a corrosive environment, it is recommended that non-rusting screws are used externally.

Order code **H07**

Vibration-proof version

Continuous vibration resistance to class 3M4 according to IEC 721-3-3:1994 (order code **H02** in combination with order code **G01, G02, G04, G05, G06, G11, and G12** or **F70, G18, G19, G44, G45, Y71, Y74, Y76, Y79** on request only).

Order code **H02**

For Constr. other than IMB, please enquire.

Arrangement of Lifting Hook / Eye Bolt (Standard)

Frame Size	Terminal Box Position	Construction	Eye Bolts/Lifting hooks(eye)	Thread Size
71	Top	B3 ¹⁾	–	–
		B5 ²⁾	–	–
80 ⁵⁾	Top	B3 ¹⁾ B5 ²⁾	Two Eye Bolt at center ⁵⁾	M8 ⁵⁾
90	Top	B3 ¹⁾ B5 ²⁾	Two Eye Bolt at center	M8
100	Top/LHS/RHS	B3 ¹⁾	2x Lifting Hooks (eye) at centre ³⁾	–
		B5 ²⁾	1x Left DE Side and 1x Right NDE Side ⁴⁾	M8
112	Top/LHS/RHS	B3 ¹⁾	Two Lifting Hooks (eye) at centre ³⁾	–
		B5 ²⁾	1x Left DE Side and 1x Right NDE Side ⁴⁾	M8
132	Top/LHS/RHS	B3 ¹⁾	Two Lifting Hooks (eye) at centre ³⁾	–
		B5 ²⁾	1x Left DE Side and 1x Right NDE Side ⁴⁾	M8
160	Top/LHS/RHS	B3 ¹⁾	Two Lifting Hooks (eye) at centre ³⁾	–
		B5 ²⁾	1x Left DE Side and 1x Right NDE Side ⁴⁾	M10
180	Top/LHS/RHS	B3 ¹⁾ B5 ²⁾	1x Left DE Side and 1x Right NDE Side ⁴⁾	M12
200	Top/LHS/RHS	B3 ¹⁾ B5 ²⁾	1x Left DE Side and 1x Right NDE Side ⁴⁾	M16
225	Top/LHS/RHS	B3 ¹⁾ B5 ²⁾	1x Left DE Side and 1x Right NDE Side ⁴⁾	M16
250	Top/LHS/RHS	B3 ¹⁾ B5 ²⁾	1x Left DE Side and 1x Right NDE Side ⁴⁾	M20
280	Top/LHS/RHS	B3 ¹⁾ B5 ²⁾	1x Left DE Side and 1x Right NDE Side ⁴⁾	M20
315	Top/LHS/RHS	B3 ¹⁾	1x Left DE Side and 1x Right NDE Side ⁴⁾	M24
		B5 ²⁾		

- 1) Eye bolt arrangement for B3 is alike for B35, B34 and other foot mounted constructions.
- 2) Eye bolt arrangement for B5 is alike for B5, B14 and other only flange mounted constructions.
- 3) Cast lifting hooks (eye) are provided approximately at center of the housing on top at left and right side.
- 4) 4x lifting eye bolt arrangement is provided. Required 2x eye bolts can be engaged based on terminal box position.
- 5) For Stator housing length >200mm need to use Eye-bolt of M8 Size.

Motor Lifting Arrangement is only provided for Lifting Motor, not to be used for Lifting with Foundation Elements.

Separately driven fan

The use of a separately driven fan is recommended to increase motor utilization at low speeds and to limit noise generation at speeds significantly higher than the synchronous speed. Both of these results can only be achieved with converter operation. Please enquire about traction and vibratory operation.

The separately driven fan can be supplied already fitted, order code **F70**. There is no automatic adjustment of the voltage for the separately driven fan when ordering a "special voltage" for the motor. This must be specified in addition using the **Y81** option.

It can also be ordered separately and retrofitted. For selection information and article numbers, see the section "Accessories" (please enquire). A rating plate listing all the important data is fitted to the separately driven fan. Please note the direction of rotation of the separately driven fan (axial-flow fan) when connecting it. Admissible coolant temperatures $CT_{min} -20^{\circ}C$, $CT_{max} +60^{\circ}C$ ¹⁾, lower/higher coolant temperatures are available on request.

When the separately driven fan is mounted, the length of the motor increases by ΔL . Please refer the general arrangement drawing for dimensions.

Brakes

Design and mode of operation

The brake takes the form of a single-disk brake with two friction surfaces.

The braking torque is generated by friction when pressure is applied by one or more pressure springs in the de-energized state. The brake is released electromagnetically.

When the motor brakes, the rotor which can be axially shifted on the hub or the shaft is pressed via the armature disk against the friction surface by means of the springs. In the braked state, there is a gap S_{Gap} between the armature disk and the solenoid component. To release the brake, the solenoid is energized with DC voltage. The resulting magnetic force pulls the armature disk against the spring force on to the solenoid component. The spring force is then no longer applied to the rotor, which can rotate freely.

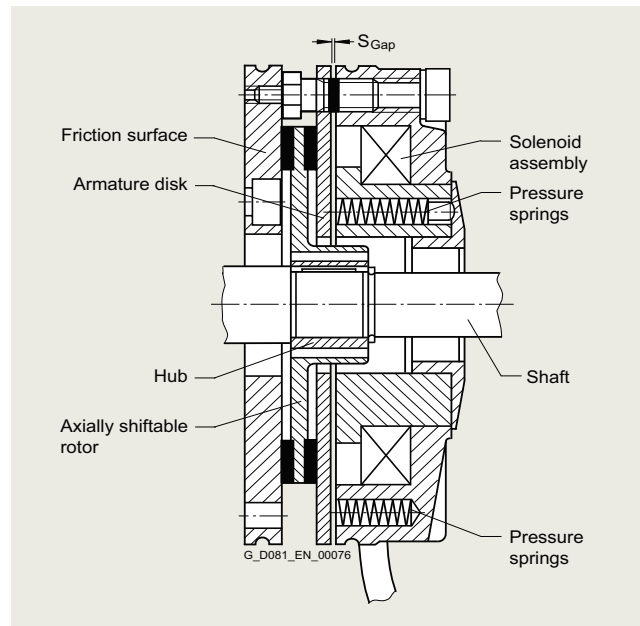

Design of the 14.458/BFK 458 spring-operated disk brake. The image above shows flange (friction surface). However the friction surface will be with friction plate or flange, based on brake size.

Rating plate

The following brake data is specified on the motor rating plate:

- Brake type
- Rectifier Supply voltage
- Frequency
- Current
- Temperature class
- Braking torque

Voltage and frequency

The solenoids and the brake rectifier are designed for connection to the following voltages or can be supplied for the following voltages:

- Brake supply voltage 24 V DC
Order code **F10**
- Brake rectifier supply voltage 230 V AC
Order code **F11**
- Brake rectifier supply voltage 400 V AC (directly at the terminal strip)
Order code **F12**
- Brake rectifier supply voltage 240 V AC (directly at the terminal strip)
Order code **F13**
- Brake rectifier supply voltage 415 V AC (directly at the terminal strip)
Order code **F14**

When 60 Hz is used, the voltage for the brake must not be increased!

Order codes **F10**, **F11**, **F12**, **F13** and **F14** must only be used in conjunction with order code **F07** or **F01**, whichever is applicable.

Lifetime of the brake lining

The braking energy L_N until readjustment of the brake depends on various factors. The main influencing factors include the masses to be braked, the operating speed, the switching frequency, and therefore the temperature at the frictional surfaces. This means it is not possible to specify a value for the friction energy until readjustment that is valid for all operating conditions.

Readjusting the air gap

Under normal operating conditions, the brake is practically maintenance-free. The air gap S_{Gap} must only be checked at regular intervals if the application requires an extremely large amount of frictional energy and readjusted to the rated air gap $S_{Gap \text{ rated}}$ at the latest when the maximum air gap $S_{Gap \text{ max}}$ is reached.

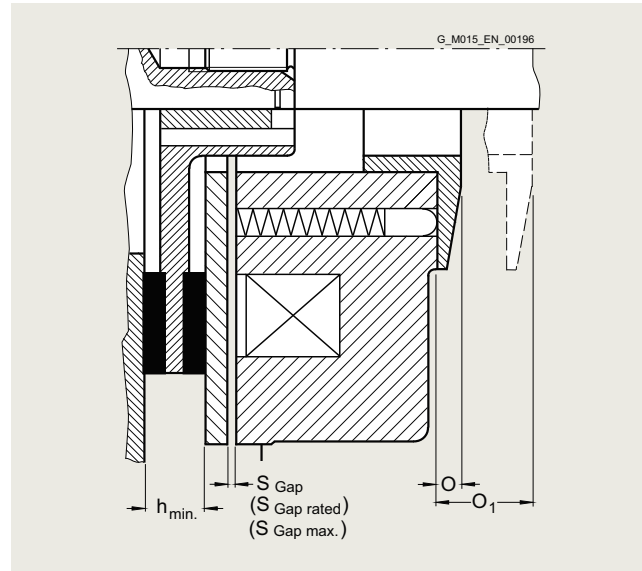

Connection

Labeled terminals are provided in the main terminal box of the motor to connect the brake.

The AC voltage for the brake excitation winding is connected to the two free terminals of the rectifier block (~).

The brake can be released when the motor is at a standstill by separately exciting the solenoid. In this case, an AC voltage must be connected at the rectifier block terminals. The brake remains released as long as this voltage is present.

For 24 V DC brakes, the brake terminals are directly connected to the DC voltage source.

Note: DC Source in the Scope of Customer

Mechanical manual brake release with lever

The brakes can be supplied with a mechanical manual release with lever.

Order code **F50**

The dimensions of the brake lever depend on the motor frame size and can be read from the dimensional drawing generator for motors in the Siemens Product Configurator (SPC) tool for low-voltage motors.

Selection and ordering data

Selection and ordering data for 2pole IE2 efficiency class motors

Operating values at rated output												Cast-iron series		m _{IM B3}	GD ² of Rotor	Torque class					
P _{rated} 50 Hz	Frame size	n _{rated} 50 Hz	T _{rated} 50 Hz	IE class	η _{rated} 50 Hz, 4/4	η _{rated} 50 Hz, 3/4	η _{rated} 50 Hz, 2/4	cos φ _{rated} 50 Hz, 4/4	I _{rated} 50 Hz, 415 V	T _{LR} T _{rated} , 50 Hz	I _{LR} I _{rated} , 50 Hz	T _g T _{rated} , 50 Hz	1LE7501 IE2 version Article No.								
kW	FS	rpm	kgfm	50 Hz	%	%	%		A	Hz	Hz	Hz		kg	kgfm ²	CL					
<ul style="list-style-type: none"> Cooling: self-ventilated (IC411) Efficiency: IE2 High Efficiency, service factor (SF) 1.15 Insulation: thermal class 155 (temperature class F), IP55 degree of protection, utilization in accordance with thermal class 130 (temperature class B) 																					
2-pole: 3000 rpm at 50 Hz																					
0.37	71 M	2763	0.13	IE2	69.5	72.2	71.2	0.80	0.93	2.6	4.3	2.5	1LE7501-0CA2	■	■	■	■	■	11	0.0011	16
0.55	71 M	2777	0.19	IE2	74.1	75.1	74.1	0.81	1.3	2.9	4.6	2.9	1LE7501-0CA3	■	■	■	■	■	11	0.0015	16
0.75	80 M	2798	0.26	IE2	77.8	77.8	77.2	0.83	1.6	2.5	4.9	2.5	1LE7501-0DA2	■	■	■	■	■	17	0.0027	16
1.1	80 M	2815	0.38	IE2	80.4	80.4	79.4	0.84	2.3	2.8	5.5	2.6	1LE7501-0DA3	■	■	■	■	■	17	0.0037	16
1.5	90 S	2880	0.51	IE2	82.1	82.1	80.0	0.85	3	3.0	6.5	3.4	1LE7501-0EA0	■	■	■	■	■	21	0.0064	16
2.2	90 L	2890	0.74	IE2	83.9	83.9	83.3	0.87	4.2	2.4	7.0	3.5	1LE7501-0EA4	■	■	■	■	■	25	0.0092	16
3.7	100 L	2845	1.3	IE2	85.9	85.9	85.9	0.87	6.9	4.0	7.0	4.0	1LE7501-1AA5	■	■	■	■	■	35	0.0156	16
5.5	132 S	2935	1.8	IE2	87.6	87.6	86.6	0.87	10	2.4	7.0	3.4	1LE7501-1CA0	■	■	■	■	■	53	0.0532	16
7.5	132 S	2925	2.5	IE2	88.6	88.6	88.6	0.90	13	2.4	7.0	3.4	1LE7501-1CA1	■	■	■	■	■	66	0.0637	16
11	160 M	2920	3.7	IE2	89.6	89.6	89.3	0.89	19	2.1	6.0	2.8	1LE7501-1DA2	■	■	■	■	■	98	0.0127	16
15	160 M	2925	5	IE2	90.6	90.6	90.4	0.90	26	2.2	6.0	3.0	1LE7501-1DA3	■	■	■	■	■	102	0.1681	16
18.5	160 L	2930	6.1	IE2	91.1	91.1	90.6	0.89	32	2.7	6.5	3.0	1LE7501-1DA4	■	■	■	■	■	123	0.1938	16
22	180 M	2930	7.3	IE2	91.5	91.5	91.3	0.90	37	2.6	6.5	3.0	1LE7501-1EA2	■	■	■	■	■	163	0.3164	16
30	200 L	2955	9.9	IE2	92.2	92.2	91.8	0.83	55	2.6	7.0	3.5	1LE7501-2AA4	■	■	■	■	■	225	0.5037	16
37	200 L	2950	12	IE2	92.6	92.6	92.2	0.87	64	2.5	7.0	3.2	1LE7501-2AA5	■	■	■	■	■	230	0.5862	16
45	225 M	2960	15	IE2	93.0	93.0	92.6	0.87	77	2.9	7.0	3.0	1LE7501-2BA2	■	■	■	■	■	295	0.9082	16
55	250 M	2975	18	IE2	94.0	94.0	93.0	0.86	95	2.8	6.8	3.0	1LE7501-2CA2	■	■	■	■	■	300	1.86	16
75	280 S	2973	25	IE2	94.2	94.0	92.8	0.87	127	2.6	6.5	3.0	1LE7501-2DA0	■	■	■	■	■	505	3.09	16
90	280 M	2977	29	IE2	94.5	94.2	93.3	0.89	149	3.5	7.0	4.0	1LE7501-2DA2	■	■	■	■	■	560	3.80	16
110	315 S	2985	36	IE2	94.5	95.0	94.5	0.90	180	2.0	6.8	2.6	1LE7501-3AA0	■	■	■	■	■	745	5.58	13
132	315 M	2982	43	IE2	95.1	95.0	93.8	0.88	219	1.9	7.0	2.7	1LE7501-3AA2	■	■	■	■	■	825	6.88	13
160	315 L	2985	52	IE2	95.3	95.2	95.2	0.92	254	2.8	7.0	3.2	1LE7501-3AA4	■	■	■	■	■	1100	9.15	16
200	315 L	2984	65	IE2	95.6	95.8	95.2	0.92	316	2.5	7.0	3.0	1LE7501-3AA6	■	■	■	■	■	1110	9.52	16
Voltages ²⁾		No. of poles		Frame size		Motor type		Version		Order code(s)											
50 Hz	240 VΔ/415 VY	2	71 M ... 90 S	1LE7501-0C ... -0E	Standard	2	3														
50 Hz	415 VΔ	2	90 L ... 315 L	1LE7501-0E ... -3A	Standard	3	5														
For other voltages ¹⁾ and more information, code letters and descriptions, please refer Page 37																					
Types of construction		No. of poles		Frame size		Motor type		Version		Order code(s)											
Without flange		IM B3 ³⁾		71 M ... 315 L		1LE7501-0C ... -3A		Standard		A											
With flange		IM B5 ³⁾		71 M ... 315 M		1LE7501-0C ... -3A		With additional charge		F											
Further types of construction and more information, code letters and descriptions, please refer Page 37																					
Motor protection		Line		No. of poles		Frame size		Motor type		Version		Order code(s)									
Without				2		71 M ... 315 L		1LE7501-0C ... -3A		Standard		A									
Further motor protection and more information, code letters and descriptions, please refer Page 38																					
Terminal box position		No. of poles		Frame size		Motor type		Version		Order code(s)											
Terminal box at top				2		71 M ... 315 L		1LE7501-0C ... -3A		Standard		4									
Further terminal box positions and more information, code letters and descriptions, please refer Page 38																					

1) Operating values at rated output for 60 Hz are stored in the Drive Technology (DT) configurator.

2) Parallel supply lines are required in the case of connection to ≤ 240V. For frame size 315 with connection to ≤ 240V, due to the high current, a drilled, removable entry plate (Order code R52) or a larger terminal box (Order code R50) can be used. Order codes R52 and R50 alter the motor dimensions.

3) Types derived from IM B3 (IM B6/7/8, IM V6 and IM V5), from IM B5 (IM V3 and IM V1) and from IM B14 (IM V19 and IM V18) are possible, provided that no requirement exists for stamping of the type on the rating plate. The basic type IM B3, IM B5 or IM B14 is stamped as standard on the rating plate. If mounted in a different position, the position must be specified to ensure that the condensation drainage holes are positioned correctly.

Selection and ordering data for 4pole IE2 efficiency class motors

Operating values at rated output												Cast-iron series		m _{IM B3}	GD ² of Rotor	Torque class	
P _{rated} 50 Hz	Frame size	n _{rated} 50 Hz	T _{rated} 50 Hz	IE class	η _{rated} 50 Hz, 4/4	η _{rated} 50 Hz, 3/4	η _{rated} 50 Hz, 2/4	cos φ _{rated} 50 Hz, 4/4	I _{rated} 50 Hz, 415 V	T _{LR} T _{rated} , 50 Hz	I _{LR} I _{rated} , 50 Hz	T _g T _{rated} , 50 Hz	1LE7501 IE2 version				Article No.
kW	FS	rpm	kgfm	50 Hz	%	%	%		A	Hz	Hz	Hz					
<ul style="list-style-type: none"> Cooling: self-ventilated (IC411) Efficiency: IE2 High Efficiency, service factor (SF) 1.15 Insulation: thermal class 155 (temperature class F), IP55 degree of protection, utilization in accordance with thermal class 130 (temperature class B) 																	
4-pole: 1500 rpm at 50 Hz																	
0.25	71 M	1380	0.17	IE2	68.5	69.6	66.4	0.69	0.74	2.5	3.7	2.5	1LE7501-0CB2	■ - ■ ■ ■ ■ ■	11	0.0026	16
0.37	71 M	1430	0.26	IE2	72.7	73.7	70.7	0.72	0.98	2.5	4.0	2.4	1LE7501-0CB3	■ - ■ ■ ■ ■ ■	12	0.0033	16
0.55	80 M	1433	0.37	IE2	77.1	77.4	73.4	0.72	1.4	2.8	5.3	2.8	1LE7501-0DB2	■ - ■ ■ ■ ■ ■	16	0.0061	16
0.75	80 M	1431	0.51	IE2	79.9	79.9	77.2	0.75	1.7	2.8	5.8	2.8	1LE7501-0DB3	■ - ■ ■ ■ ■ ■	18	0.0078	16
1.1	90 S	1431	0.75	IE2	82.2	82.2	81.6	0.78	2.4	2.8	5.7	2.8	1LE7501-0EB0	■ - ■ ■ ■ ■ ■	19	0.0100	16
1.5	90 L	1440	1	IE2	83.5	83.5	82.9	0.79	3.2	2.8	6.0	3.1	1LE7501-0EB4	■ - ■ ■ ■ ■ ■	22	0.0132	16
2.2	100 L	1445	1.5	IE2	84.3	84.3	83.3	0.76	4.8	2.8	6.6	3.0	1LE7501-1AB4	■ - ■ ■ ■ ■ ■	31	0.0279	16
3.7	112 M	1450	2.5	IE2	86.3	86.3	86.0	0.81	7.4	2.6	6.5	2.9	1LE7501-1BB2	■ - ■ ■ ■ ■ ■	43	0.0422	16
5.5	132 S	1455	3.7	IE2	87.7	87.7	86.7	0.79	11	2.4	6.8	2.8	1LE7501-1CB0	■ - ■ ■ ■ ■ ■	68	0.0792	13
7.5	132 M	1465	5	IE2	88.7	88.7	87.7	0.79	15	2.6	7.0	2.5	1LE7501-1CB2	■ - ■ ■ ■ ■ ■	70	0.1059	13
11	160 M	1455	7.3	IE2	89.8	89.8	87.3	0.80	21	2.9	7.0	2.9	1LE7501-1DB2	■ - ■ ■ ■ ■ ■	96	0.1857	16
15	160 L	1465	10	IE2	90.7	90.7	90.3	0.84	27	2.9	7.0	2.9	1LE7501-1DB4	■ - ■ ■ ■ ■ ■	97	0.2425	16
18.5	180 M	1465	12	IE2	91.2	91.2	90.8	0.82	34	2.7	7.0	2.9	1LE7501-1EB2	■ - ■ ■ ■ ■ ■	160	0.5000	16
22	180 L	1470	15	IE2	91.8	91.8	91.5	0.83	40	2.9	7.0	2.9	1LE7501-1EB4	■ - ■ ■ ■ ■ ■	165	0.5534	16
30	200 L	1470	20	IE2	92.3	92.3	92.0	0.80	57	2.7	7.0	3.2	1LE7501-2AB5	■ - ■ ■ ■ ■ ■	234	0.7810	16
37	225 S	1475	25	IE2	92.7	92.7	92.4	0.87	64	2.6	7.0	3.0	1LE7501-2BB0	■ - ■ ■ ■ ■ ■	298	1.7562	16
45	225 M	1485	30	IE2	93.2	93.2	93.0	0.87	77	2.8	7.0	3.1	1LE7501-2BB2	■ - ■ ■ ■ ■ ■	314	2.0756	16
55	250 M	1485	36	IE2	93.8	94.3	93.3	0.81	101	3.0	7.0	3.5	1LE7501-2CB2	■ - ■ ■ ■ ■ ■	396	3.25	16
75	280 S	1486	49	IE2	94.0	95.0	94.0	0.83	134	3.0	7.0	3.5	1LE7501-2DB0	■ - ■ ■ ■ ■ ■	555	5.49	16
90	280 M	1485	59	IE2	94.2	94.2	94.2	0.83	160	3.0	7.0	3.5	1LE7501-2DB2	■ - ■ ■ ■ ■ ■	605	6.48	16
110	315 S	1488	72	IE2	94.8	95.4	95.4	0.85	190	2.5	6.8	3.5	1LE7501-3AB0	■ - ■ ■ ■ ■ ■	735	8.78	16
132	315 M	1489	86	IE2	94.9	94.9	94.9	0.85	228	2.8	7.0	2.5	1LE7501-3AB2	■ - ■ ■ ■ ■ ■	905	10.75	16
160	315 L	1487	105	IE2	95.1	95.1	95.1	0.87	269	2.5	7.0	2.5	1LE7501-3AB4	■ - ■ ■ ■ ■ ■	950	13.75	16
200	315 L	1490	131	IE2	95.6	96.0	96.0	0.87	335	2.9	7.0	2.7	1LE7501-3AB6	■ - ■ ■ ■ ■ ■	1180	17.42	16
Voltages ²⁾		No. of poles		Frame size		Motor type		Version				Order code(s)					
50 Hz	240 VΔ/415 VY	4	71 M ... 90L	1LE7501-0C ... -0E	Standard	2	3						-				
50 Hz	415 VΔ	4	100L ... 315 L	1LE7501-1A ... -3A	Standard	3	5						-				
For other voltages ¹⁾ and more information, code letters and descriptions, please refer Page 37																	
Types of construction		No. of poles		Frame size		Motor type		Version				Order code(s)					
Without flange		IM B3 ³⁾		71 M ... 315 L		1LE7501-0C ... -3A		Standard				A					
With flange		IM B5 ³⁾		71 M ... 315 M		1LE7501-0C ... -3A		With additional charge				F					
Further types of construction and more information, code letters and descriptions, please refer Page 37																	
Motor protection		Line		No. of poles		Frame size		Motor type		Version		Order code(s)					
Without				4		71 M ... 315 L		1LE7501-0C ... -3A		Standard		A					
Further motor protection and more information, code letters and descriptions, please refer Page 38																	
Terminal box position		No. of poles		Frame size		Motor type		Version				Order code(s)					
Terminal box at top		4		71 M ... 315 L		1LE7501-0C ... -3A		Standard				4					
Further terminal box positions and more information, code letters and descriptions, please refer Page 38																	

1) Operating values at rated output for 60 Hz are stored in the Drive Technology (DT) configurator.

2) Parallel supply lines are required in the case of connection to ≤ 240V. For frame size 315 with connection to ≤ 240V, due to the high current, a drilled, removable entry plate (Order code R52) or a larger terminal box (Order code R50) can be used. Order codes R52 and R50 alter the motor dimensions.

3) Types derived from IM B3 (IM B6/7/8, IM V6 and IM V5), from IM B5 (IM V3 and IM V1) and from IM B14 (IM V19 and IM V18) are possible, provided that no requirement exists for stamping of the type on the rating plate. The basic type IM B3, IM B5 or IM B14 is stamped as standard on the rating plate. If mounted in a different position, the position must be specified to ensure that the condensation drainage holes are positioned correctly.

Selection and ordering data for 6-pole IE2 efficiency class motors

Operating values at rated output													Cast-iron series			
P_{rated} 50 Hz	Frame size	n_{rated} 50 Hz	T_{rated} 50 Hz	IE class	η_{rated} 50 Hz, 4/4	η_{rated} 50 Hz, 3/4	η_{rated} 50 Hz, 2/4	$\cos \phi_{rated}$ 50 Hz, 4/4	I_{rated} 50 Hz, 415 V	T_{LR} 50 Hz	I_{LR} 50 Hz	T_g T_{rated} , 50 Hz	1LE7501 IE2 version Article No.	$m_{IM B3}$	GD ² of Rotor	Torque class
kW	FS	rpm	kgfm	50 Hz	%	%	%		A	Hz	Hz	50 Hz		kg	kgfm ²	CL
<ul style="list-style-type: none"> Cooling: self-ventilated (IC411) Efficiency: IE2 High Efficiency, service factor (SF) 1.15 Insulation: thermal class 155 (temperature class F), IP55 degree of protection, utilization in accordance with thermal class 130 (temperature class B) 																
6-pole: 1000 rpm at 50 Hz																
0.18	71 M	894	0.2	IE2	56.6	57.9	56.9	0.69	0.64	2.2	2.5	2.5	1LE7501-0CC2	11	0.0029	16
0.25	71 M	880	0.28	IE2	61.6	62.8	61.8	0.70	0.81	2.3	2.8	2.4	1LE7501-0CC3	11	0.0036	16
0.37	80 M	925	0.39	IE2	67.6	69.0	65.0	0.69	1.1	2.1	4.0	2.4	1LE7501-0DC2	14	0.0063	16
0.55	80 M	938	0.57	IE2	73.1	74.1	72.0	0.67	1.6	2.5	4.4	2.9	1LE7501-0DC3	17	0.0090	16
0.75	90 S	937	0.78	IE2	76.8	76.8	75.8	0.72	1.9	2.0	4.1	2.4	1LE7501-0EC0	19	0.0124	16
1.1	90 L	940	1.1	IE2	79.0	79.0	78.0	0.72	2.7	2.2	4.4	2.4	1LE7501-0EC4	26	0.0171	16
1.5	100 L	945	1.5	IE2	80.6	80.6	80.6	0.74	3.5	2.3	5.2	2.5	1LE7501-1AC4	30	0.0310	16
2.2	112 M	945	2.3	IE2	82.6	82.6	82.6	0.73	5.1	2.6	5.5	2.6	1LE7501-1BC2	42	0.0432	16
3.7	132 S	965	3.7	IE2	84.8	84.8	83.0	0.70	8.7	2.6	6.0	2.8	1LE7501-1CC1	61	0.0842	16
5.5	132 M	965	5.6	IE2	86.5	86.3	84.0	0.70	13	2.6	6.0	2.8	1LE7501-1CC3	73	0.1165	13
7.5	160 M	975	7.5	IE2	87.3	87.3	87.0	0.78	15	2.5	6.0	2.6	1LE7501-1DC2	90	0.3985	16
11	160 L	975	11	IE2	88.9	88.9	88.6	0.78	22	2.5	6.0	2.6	1LE7501-1DC4	102	0.5618	16
15	180 L	970	15	IE2	89.9	89.9	89.6	0.78	30	2.2	6.0	2.4	1LE7501-1EC4	200	0.7441	13
18.5	200 L	980	18	IE2	90.6	90.6	90.3	0.79	36	2.8	6.0	2.8	1LE7501-2AC4	231	1.0634	16
22	200 L	980	22	IE2	91.1	91.1	90.8	0.81	41	2.4	6.5	2.3	1LE7501-2AC5	232	1.2738	13
30	225 M	980	30	IE2	91.9	91.9	91.6	0.81	56	2.9	6.5	3.0	1LE7501-2BC2	296	2.4027	16
37	250 M	983	37	IE2	93.0	93.3	93.0	0.81	68	2.5	6.6	3.0	1LE7501-2CC2	370	3.55	16
45	280 S	986	44	IE2	93.4	93.6	93.3	0.79	85	3.0	7.0	3.0	1LE7501-2DC0	515	4.41	16
55	280 M	987	54	IE2	93.6	93.8	93.5	0.77	106	3.5	7.0	3.0	1LE7501-2DC2	520	5.86	16
75	315 S	990	74	IE2	93.9	95.0	94.0	0.80	139	3.0	7.0	3.3	1LE7501-3AC0	660	9.46	16
90	315 M	990	89	IE2	94.2	95.2	94.5	0.83	160	2.6	6.8	2.5	1LE7501-3AC2	740	11.19	16
110	315 L	990	108	IE2	94.5	95.4	94.7	0.85	191	2.7	7.0	2.6	1LE7501-3AC4	860	14.85	16
132	315 L	990	130	IE2	94.8	95.8	95.0	0.84	231	3.0	7.0	2.7	1LE7501-3AC6	940	16.86	16
Voltages ²⁾		No. of poles		Frame size		Motor type		Version		Order code(s)						
50 Hz	240 VΔ/415 VY	6	71 M ... 100 L	1LE7501-0C ... -1A	Standard	2	3	-								
50 Hz	415 VΔ	6	112 M ... 315 L	1LE7501-1B ... -3A	Standard	3	5	-								
For other voltages ¹⁾ and more information, code letters and descriptions, please refer Page 37																
Types of construction		No. of poles		Frame size		Motor type		Version		Order code(s)						
Without flange	IM B3 ³⁾	6	71 M ... 315 L	1LE7501-0C ... -3A	Standard	A		-								
With flange	IM B5 ³⁾	6	71 M ... 315 M	1LE7501-0C ... -3A	With additional charge	F		-								
Further types of construction and more information, code letters and descriptions, please refer Page 37																
Motor protection		Line		No. of poles		Frame size		Motor type		Version		Order code(s)				
Without		6	71 M ... 315 L	1LE7501-0C ... -3A	Standard	A		-								
Further motor protection and more information, code letters and descriptions, please refer Page 38																
Terminal box position		No. of poles		Frame size		Motor type		Version		Order code(s)						
Terminal box at top		2	71 M ... 315 L	1LE7501-0C ... -3A	Standard	4		-								
Further terminal box positions and more information, code letters and descriptions, please refer Page 38																

1) Operating values at rated output for 60 Hz are stored in the Drive Technology (DT) configurator.

2) Parallel supply lines are required in the case of connection to ≤ 240V. For frame size 315 with connection to ≤ 240V, due to the high current, a drilled, removable entry plate (Order code R52) or a larger terminal box (Order code R50) can be used. Order codes R52 and R50 alter the motor dimensions.

3) Types derived from IM B3 (IM B6/7/8, IM V6 and IM V5), from IM B5 (IM V3 and IM V1) and from IM B14 (IM V19 and IM V18) are possible, provided that no requirement exists for stamping of the type on the rating plate. The basic type IM B3, IM B5 or IM B14 is stamped as standard on the rating plate. If mounted in a different position, the position must be specified to ensure that the condensation drainage holes are positioned correctly.

Selection and ordering data for 2pole IE3 efficiency class motors

Operating values at rated output												Cast-iron series		m _{IM B3}	GD ² of Rotor	Torque class	
P _{rated} 50 Hz	Frame size	n _{rated} 50 Hz	T _{rated} 50 Hz	IE class	η _{rated} 50 Hz, 4/4	η _{rated} 50 Hz, 3/4	η _{rated} 50 Hz, 2/4	cos φ _{rated} 50 Hz, 4/4	I _{rated} 50 Hz, 415 V	T _{LR} T _{rated} 50 Hz	I _{LR} I _{rated} 50 Hz	T _g T _{rated} 50 Hz	1LE7503 IE3 version Article No.				kg
kW	FS	rpm	kgfm	50 Hz	%	%	%		A	Hz	Hz	Hz					
<ul style="list-style-type: none"> Cooling: self-ventilated (IC411) Efficiency: IE3 Premium Efficiency, service factor (SF) 1.15 Insulation: thermal class 155 (temperature class F), IP55 degree of protection, utilization in accordance with thermal class 130 (temperature class B) 																	
2-pole: 3000 rpm at 50 Hz																	
0.37	71 M	2800	0.13	IE3	74.8	73.8	68.0	0.78	0.88	2.5	4.5	2.5	1LE7503-0CA2	11	0.0011	16	
0.55	71 M	2780	0.19	IE3	77.8	77.8	74.0	0.81	1.2	2.5	5.0	2.5	1LE7503-0CA3	11	0.0015	16	
0.75	80 M	2850	0.26	IE3	81.4	82.0	80.0	0.83	1.5	2.5	6.0	2.7	1LE7503-0DA2	18	0.0032	13	
1.1	80 M	2853	0.38	IE3	82.7	83.5	82.2	0.84	2.2	3.4	7.0	3.4	1LE7503-0DA3	18	0.0044	16	
1.5	90 S	2880	0.51	IE3	84.9	84.9	84.9	0.86	2.9	2.5	7.0	3.5	1LE7503-0EA0	23	0.0082	10	
2.2	90 L	2900	0.74	IE3	86.8	87.5	86.8	0.89	4	3.6	7.5	3.8	1LE7503-0EA4	30	0.0102	16	
3.7	100 L	2859	1.3	IE3	87.8	88.5	88.1	0.89	6.6	4.2	7.7	4.0	1LE7503-1AA5	38	0.0190	16	
5.5	132 S	2936	1.8	IE3	89.8	90.5	89.4	0.91	9.4	2.4	7.2	3.0	1LE7503-1CA0	58	0.0641	10	
7.5	132 S	2935	2.5	IE3	90.1	90.6	88.0	0.85	14	3.0	7.7	3.9	1LE7503-1CA1	67	0.0659	16	
11	160 M	2947	3.6	IE3	91.5	91.5	90.5	0.88	19	2.8	7.2	3.5	1LE7503-1DA2	120	0.1681	16	
15	160 M	2950	5.0	IE3	91.9	91.8	90.5	0.88	26	3.0	7.4	3.5	1LE7503-1DA3	122	0.1938	16	
18.5	160 L	2949	6.1	IE3	92.7	92.9	92.2	0.88	32	3.1	7.7	4.0	1LE7503-1DA4	137	0.2443	16	
22	180 M	2944	7.3	IE3	92.7	92.9	91.9	0.88	38	3.0	7.3	3.2	1LE7503-1EA2	180	0.3164	16	
30	200 L	2963	9.9	IE3	93.3	93.3	92.4	0.83	54	2.5	7.0	3.3	1LE7503-2AA4	230	0.5063	16	
37	200 L	2960	12	IE3	93.8	93.5	92.0	0.85	65	2.5	7.3	3.3	1LE7503-2AA5	235	0.6256	16	
45	225 M	2965	15	IE3	94.0	94.1	93.5	0.87	77	3.0	7.7	3.6	1LE7503-2BA2	323	0.9912	16	
55	250 M	2970	18	IE3	94.4	94.4	94.1	0.88	92	2.1	6.5	2.8	1LE7503-2CA2	335	1.86	13	
75	280 S	2972	25	IE3	94.8	95.0	94.5	0.87	127	2.2	6.5	2.8	1LE7503-2DA0	535	3.09	13	
90	280 M	2977	29	IE3	95.4	95.6	95.0	0.88	149	2.6	7.7	3.0	1LE7503-2DA2	595	4.18	13	
110	315 S	2982	36	IE3	95.5	95.7	95.4	0.90	178	2.4	7.0	2.8	1LE7503-3AA0	810	5.58	10	
132	315 M	2982	43	IE3	95.9	96.0	95.6	0.91	210	2.5	7.3	2.6	1LE7503-3AA2	900	6.90	10	
160	315 L	2982	52	IE3	96.0	96.2	95.8	0.91	255	2.5	7.2	2.7	1LE7503-3AA4	1180	9.52	10	
200	315 L	2982	65	IE3	96.0	96.2	95.9	0.92	315	2.4	7.0	2.5	1LE7503-3AA6	1190	10.45	10	
Voltages ²⁾		No. of poles	Frame size	Motor type	Version	Order code(s)											
50 Hz	240 VΔ/415 VY	2	71 M ... 90 S	1LE7503-OC ... -0E	Standard	2	3										
50 Hz	415 VΔ	2	90 L ... 315 L	1LE7503-0E ... -3A	Standard	3	5										
For other voltages ¹⁾ and more information, code letters and descriptions, please refer Page 37																	
Types of construction		No. of poles	Frame size	Motor type	Version	Order code(s)											
Without flange		IM B3 ³⁾	71 M ... 315 L	1LE7503-OC ... -3A	Standard	A											
With flange		IM B5 ³⁾	71 M ... 315 M	1LE7503-OC ... -3A	With additional charge	F											
Further types of construction and more information, code letters and descriptions, please refer Page 37																	
Motor protection		Line	No. of poles	Frame size	Motor type	Version	Order code(s)										
Without			2	71 M ... 315 L	1LE7503-OC ... -3A	Standard	A										
Further motor protection and more information, code letters and descriptions, please refer Page 38																	
Terminal box position		No. of poles	Frame size	Motor type	Version	Order code(s)											
Terminal box at top			2	71 M ... 315 L	1LE7503-OC ... -3A	Standard	4										
Further terminal box positions and more information, code letters and descriptions, please refer Page 38																	

1) Operating values at rated output for 60 Hz are stored in the Drive Technology (DT) configurator.
 2) Parallel supply lines are required in the case of connection to ≤ 240V. For frame size 315 with connection to ≤ 240V, due to the high current, a drilled, removable entry plate (Order code R52) or a larger terminal box (Order code R50) can be used. Order codes R52 and R50 alter the motor dimensions.

3) Types derived from IM B3 (IM B6/7/8, IM V6 and IM V5), from IM B5 (IM V3 and IM V1) and from IM B14 (IM V19 and IM V18) are possible, provided that no requirement exists for stamping of the type on the rating plate. The basic type IM B3, IM B5 or IM B14 is stamped as standard on the rating plate. If mounted in a different position, the position must be specified to ensure that the condensation drainage holes are positioned correctly.

Selection and ordering data for 4pole IE3 efficiency class motors

Operating values at rated output													Cast-iron series		m _{IM B3}	GD ² of Rotor	Torque class
P _{rated} 50 Hz	Frame size	n _{rated} 50 Hz	T _{rated} 50 Hz	IE class	η _{rated} 50 Hz, 4/4	η _{rated} 50 Hz, 3/4	η _{rated} 50 Hz, 2/4	cos φ _{rated} 50 Hz, 4/4	I _{rated} 50 Hz, 415 V	T _{LR} T _{rated} , 50 Hz	I _{LR} I _{rated} , 50 Hz	T _g T _{rated} , 50 Hz	1LE7503 IE3 version	Article No.			
kW	FS	rpm	kgfm	50 Hz	%	%	%		A	Hz	Hz	Hz					
<ul style="list-style-type: none"> Cooling: self-ventilated (IC411) Efficiency: IE3 Premium Efficiency, service factor (SF) 1.15 Insulation: thermal class 155 (temperature class F), IP55 degree of protection, utilization in accordance with thermal class 130 (temperature class B) 																	
4-pole: 1500 rpm at 50 Hz																	
0.25	71 M	1425	0.17	IE3	75.0	74.0	65.0	0.60	0.77	2.5	4.5	3.7	1LE7503-0CB2	■ - ■ ■ ■ ■ ■ ■	12	0.0026	16
0.37	71 M	1395	0.26	IE3	78.0	78.0	75.0	0.67	0.99	3.0	4.5	2.7	1LE7503-0CB3	■ - ■ ■ ■ ■ ■ ■	13	0.0033	16
0.55	80 M	1440	0.37	IE3	81.4	81.4	78.5	0.76	1.2	2.6	5.5	2.7	1LE7503-0DB2	■ - ■ ■ ■ ■ ■ ■	17	0.0070	16
0.75	80 M	1445	0.51	IE3	83.2	83.2	82.0	0.75	1.7	3.5	6.5	3.2	1LE7503-0DB3	■ - ■ ■ ■ ■ ■ ■	21	0.0095	16
1.1	90 S	1442	0.74	IE3	84.7	85.2	83.3	0.77	2.3	3.4	6.5	4.0	1LE7503-0EB0	■ - ■ ■ ■ ■ ■ ■	24	0.0135	16
1.5	90 L	1445	1	IE3	85.6	85.8	84.0	0.78	3.1	3.1	6.5	3.2	1LE7503-0EB4	■ - ■ ■ ■ ■ ■ ■	29	0.0175	13
2.2	100 L	1448	1.5	IE3	87.2	87.5	86.0	0.78	4.5	3.2	7.5	3.2	1LE7503-1AB4	■ - ■ ■ ■ ■ ■ ■	37	0.0361	13
3.7	112 M	1451	2.5	IE3	88.4	88.6	87.6	0.81	7.2	3.2	7.5	4.2	1LE7503-1BB2	■ - ■ ■ ■ ■ ■ ■	51	0.0508	16
5.5	132 S	1465	3.7	IE3	90.1	90.1	89.6	0.80	11	3.0	7.5	3.2	1LE7503-1CB0	■ - ■ ■ ■ ■ ■ ■	69	0.1090	16
7.5	132 M	1459	5	IE3	90.4	91.0	90.5	0.85	14	2.8	6.5	3.5	1LE7503-1CB2	■ - ■ ■ ■ ■ ■ ■	90	0.1342	16
11	160 M	1469	7.3	IE3	91.6	91.6	90.6	0.83	20	3.0	7.5	3.5	1LE7503-1DB2	■ - ■ ■ ■ ■ ■ ■	120	0.2492	16
15	160 L	1467	10	IE3	92.1	92.3	91.5	0.82	28	3.2	7.5	4.0	1LE7503-1DB4	■ - ■ ■ ■ ■ ■ ■	133	0.3528	16
18.5	180 M	1472	12	IE3	92.6	93.0	92.5	0.82	34	2.9	7.5	2.9	1LE7503-1EB2	■ - ■ ■ ■ ■ ■ ■	162	0.4872	16
22	180 L	1472	15	IE3	93.0	93.4	92.9	0.83	40	2.9	7.4	2.9	1LE7503-1EB4	■ - ■ ■ ■ ■ ■ ■	183	0.5924	13
30	200 L	1478	20	IE3	93.8	93.9	93.0	0.78	57	3.0	7.5	3.9	1LE7503-2AB5	■ - ■ ■ ■ ■ ■ ■	241	0.9972	16
37	225 S	1479	24	IE3	94.2	94.5	94.3	0.85	64	3.5	7.5	4.0	1LE7503-2BB0	■ - ■ ■ ■ ■ ■ ■	354	2.4664	16
45	225 M	1478	30	IE3	94.3	94.7	94.5	0.86	77	3.5	7.5	4.0	1LE7503-2BB2	■ - ■ ■ ■ ■ ■ ■	361	2.6612	13
55	250 M	1485	36	IE3	94.7	94.9	94.5	0.84	96	3.0	7.0	3.3	1LE7503-2CB2	■ - ■ ■ ■ ■ ■ ■	447	3.53	13
75	280 S	1486	49	IE3	95.1	95.3	94.6	0.83	132	2.8	7.2	3.2	1LE7503-2DB0	■ - ■ ■ ■ ■ ■ ■	590	5.49	16
90	280 M	1487	59	IE3	95.2	95.1	94.2	0.82	160	3.2	7.7	3.3	1LE7503-2DB2	■ - ■ ■ ■ ■ ■ ■	668	6.8	16
110	315 S	1487	72	IE3	95.5	95.7	95.5	0.86	186	3.0	7.3	3.2	1LE7503-3AB0	■ - ■ ■ ■ ■ ■ ■	793	9.02	10
132	315 M	1489	86	IE3	95.9	96.0	95.6	0.87	220	2.7	7.5	3.0	1LE7503-3AB2	■ - ■ ■ ■ ■ ■ ■	935	10.75	13
160	315 L	1489	105	IE3	95.9	96.1	95.8	0.87	267	3.0	7.7	3.2	1LE7503-3AB4	■ - ■ ■ ■ ■ ■ ■	1028	13.75	16
200	315 L	1490	131	IE3	96.2	96.3	96.0	0.87	332	3.0	7.5	3.0	1LE7503-3AB6	■ - ■ ■ ■ ■ ■ ■	1220	17.42	16
Voltages ²⁾				No. of poles	Frame size		Motor type		Version						Order code(s)		
50 Hz	240 VΔ/415 VY			4	71 M ... 90 L		1LE7503-0C ... -0E		Standard				2	3			-
50 Hz	415 VΔ			4	100L ... 315 L		1LE7503-1A ... -3A		Standard				3	5			-
For other voltages ¹⁾ and more information, code letters and descriptions, please refer Page 37																	
Types of construction				No. of poles	Frame size		Motor type		Version						Order code(s)		
Without flange		IM B3 ³⁾		4	71 M ... 315 L		1LE7503-0C ... -3A		Standard				A				-
With flange		IM B5 ³⁾		4	71 M ... 315 M		1LE7503-0C ... -3A		With additional charge				F				-
Further types of construction and more information, code letters and descriptions, please refer Page 37																	
Motor protection		Line		No. of poles	Frame size		Motor type		Version						Order code(s)		
Without				4	71 M ... 315 L		1LE7503-0C ... -3A		Standard				A				-
Further motor protection and more information, code letters and descriptions, please refer Page 38																	
Terminal box position				No. of poles	Frame size		Motor type		Version						Order code(s)		
Terminal box at top				4	71 M ... 315 L		1LE7503-0C ... -3A		Standard				4				-
Further terminal box positions and more information, code letters and descriptions, please refer Page 38																	

1) Operating values at rated output for 60Hz are stored in the Drive Technology (DT) configurator.
 2) Parallel supply lines are required in the case of connection to ≤ 240V. For frame size 315 with connection to ≤ 240V, due to the high current, a drilled, removable entry plate (Order code R52) or a larger terminal box (Order code R50) can be used. Order codes R52 and R50 alter the motor dimensions.

3) Types derived from IM B3 (IM B6/7/8, IM V6 and IM V5), from IM B5 (IM V3 and IM V1) and from IM B14 (IM V19 and IM V18) are possible, provided that no requirement exists for stamping of the type on the rating plate. The basic type IM B3, IM B5 or IM B14 is stamped as standard on the rating plate. If mounted in a different position, the position must be specified to ensure that the condensation drainage holes are positioned correctly.

Selection and ordering data for 6-pole IE3 efficiency class motors

Operating values at rated output													Cast-iron series		m _{IM B3}	GD ² of Rotor	Torque class
P _{rated} 50 Hz	Frame size	n _{rated} 50 Hz	T _{rated} 50 Hz	IE class	η _{rated} 50 Hz, 4/4	η _{rated} 50 Hz, 3/4	η _{rated} 50 Hz, 2/4	cos φ _{rated} 50 Hz, 4/4	I _{rated} 50 Hz, 415 V	T _{LR} T _{rated} , 50 Hz	I _{LR} I _{rated} , 50 Hz	T _g T _{rated} , 50 Hz	1LE7503 IE3 version	Article No.			
kW	FS	rpm	kgf·m	50 Hz	%	%	%		A	Hz	Hz	Hz					
<ul style="list-style-type: none"> Cooling: self-ventilated (IC411) Efficiency: IE3 Premium Efficiency, service factor (SF) 1.15 Insulation: thermal class 155 (temperature class F), IP55 degree of protection, utilization in accordance with thermal class 130 (temperature class B) 																	
6-pole: 1000 rpm at 50 Hz																	
0.18	71 M	885	0.2	IE3	65.1	65.1	64.0	0.70	0.55	2.0	2.5	2.3	1LE7503-0CC2	■ - ■ ■ ■ ■ ■ ■	12	0.0028	13
0.25	71 M	910	0.27	IE3	70.0	70.0	66.0	0.64	0.78	2.5	3.0	2.7	1LE7503-0CC3	■ - ■ ■ ■ ■ ■ ■	11	0.0036	16
0.37	80 M	945	0.38	IE3	74.5	74.5	72.0	0.63	1.1	2.5	4.0	2.6	1LE7503-0DC2	■ - ■ ■ ■ ■ ■ ■	17	0.0072	16
0.55	80 M	935	0.57	IE3	77.2	77.2	73.0	0.68	1.5	2.5	4.0	2.6	1LE7503-0DC3	■ - ■ ■ ■ ■ ■ ■	21	0.0103	16
0.75	90 S	940	0.78	IE3	78.9	80.0	78.0	0.71	1.9	2.0	4.5	2.6	1LE7503-0EC0	■ - ■ ■ ■ ■ ■ ■	22	0.0124	13
1.1	90 L	972	1.1	IE3	81.5	81.5	80.0	0.71	2.6	2.0	4.5	2.5	1LE7503-0EC4	■ - ■ ■ ■ ■ ■ ■	28	0.0171	10
1.5	100 L	953	1.5	IE3	83.6	84.4	82.8	0.73	3.4	2.8	5.0	3.1	1LE7503-1AC4	■ - ■ ■ ■ ■ ■ ■	33	0.0335	16
2.2	112 M	960	2.2	IE3	85.2	85.0	82.8	0.67	5.4	3.5	6.0	3.0	1LE7503-1BC2	■ - ■ ■ ■ ■ ■ ■	44	0.0446	16
3.7	132 S	962	3.7	IE3	86.8	87.5	86.5	0.75	7.9	2.6	5.0	3.0	1LE7503-1CC1	■ - ■ ■ ■ ■ ■ ■	66	0.0955	13
5.5	132 M	966	5.5	IE3	88.8	89.3	88	0.7	12	3.4	6.6	3.8	1LE7503-1CC3	■ - ■ ■ ■ ■ ■ ■	79	0.1393	16
7.5	160 M	979	7.5	IE3	89.4	89.4	88.4	0.76	15	3.2	5.6	3.0	1LE7503-1DC2	■ - ■ ■ ■ ■ ■ ■	121	0.4559	16
11	160 L	981	11	IE3	90.5	90.5	89.0	0.73	23	3.5	7.0	3.7	1LE7503-1DC4	■ - ■ ■ ■ ■ ■ ■	127	0.6509	16
15	180 L	978	15	IE3	91.2	91.6	90.7	0.73	31	2.8	6.3	3.0	1LE7503-1EC4	■ - ■ ■ ■ ■ ■ ■	220	0.7844	16
18.5	200 L	982	18	IE3	92.2	92.5	91.8	0.78	36	3.0	7.0	3.2	1LE7503-2AC4	■ - ■ ■ ■ ■ ■ ■	238	1.4064	16
22	200 L	982	22	IE3	92.5	92.8	92.0	0.78	42	3.8	7.0	2.8	1LE7503-2AC5	■ - ■ ■ ■ ■ ■ ■	240	1.6331	13
30	225 M	985	30	IE3	93.1	93.1	92.1	0.8	56	3.4	7.5	3.5	1LE7503-2BC2	■ - ■ ■ ■ ■ ■ ■	310	2.7662	16
37	250 M	986	37	IE3	93.6	94.0	93.6	0.83	66	3.2	7.5	4.0	1LE7503-2CC2	■ - ■ ■ ■ ■ ■ ■	410	5.2	16
45	280 S	988	44	IE3	93.8	94.2	93.6	0.82	81	2.7	7.3	3.0	1LE7503-2DC0	■ - ■ ■ ■ ■ ■ ■	555	5.5	16
55	280 M	988	54	IE3	94.1	94.5	94.1	0.82	99	3.0	7.5	3.0	1LE7503-2DC2	■ - ■ ■ ■ ■ ■ ■	560	6.35	16
75	315 S	991	74	IE3	95.1	95.3	95.0	0.82	134	3.1	7.1	3.1	1LE7503-3AC0	■ - ■ ■ ■ ■ ■ ■	760	10.42	16
90	315 M	990	89	IE3	95.2	95.5	95.1	0.84	157	2.6	7.0	2.9	1LE7503-3AC2	■ - ■ ■ ■ ■ ■ ■	850	12.37	16
110	315 L	991	108	IE3	95.6	95.7	95.5	0.85	188	3.0	7.5	3.2	1LE7503-3AC4	■ - ■ ■ ■ ■ ■ ■	1020	16.78	16
132	315 L	990	130	IE3	95.8	95.9	95.7	0.86	223	3.0	7.5	3.3	1LE7503-3AC6	■ - ■ ■ ■ ■ ■ ■	1050	18.59	16
Voltagess²⁾				No. of poles	Frame size		Motor type		Version				Order code(s)				
50 Hz	240 VΔ/415 VY			6	71 M ... 100 L		1LE7503-0C ... -1A		Standard				2	3	-		
50 Hz	415 VΔ			6	112 M ... 315 L		1LE7503-1B ... -3A		Standard				3	5	-		
For other voltages ¹⁾ and more information, code letters and descriptions, please refer Page 37																	
Types of construction				No. of poles	Frame size		Motor type		Version						Order code(s)		
Without flange		IM B3 ³⁾		6	71 M ... 315 L		1LE7503-0C ... -3A		Standard				A		-		
With flange		IM B5 ³⁾		6	71 M ... 315 M		1LE7503-0C ... -3A		With additional charge				F		-		
Further types of construction and more information, code letters and descriptions, please refer Page 37																	
Motor protection		Line		No. of poles	Frame size		Motor type		Version						Order code(s)		
Without				6	71 M ... 315 L		1LE7503-0C ... -3A		Standard				A		-		
Further motor protection and more information, code letters and descriptions, please refer Page 38																	
Terminal box position				No. of poles	Frame size		Motor type		Version						Order code(s)		
Terminal box at top				6	71 M ... 315 L		1LE7503-0C ... -3A		Standard				4		-		
Further terminal box positions and more information, code letters and descriptions, please refer Page 38																	

1) Operating values at rated output for 60Hz are stored in the Drive Technology (DT) configurator.

2) Parallel supply lines are required in the case of connection to ≤ 240V. For frame size 315 with connection to ≤ 240V, due to the high current, a drilled, removable entry plate (Order code R52) or a larger terminal box (Order code R50) can be used. Order codes R52 and R50 alter the motor dimensions.

3) Types derived from IM B3 (IM B6/7/8, IM V6 and IM V5), from IM B5 (IM V3 and IM V1) and from IM B14 (IM V19 and IM V18) are possible, provided that no requirement exists for stamping of the type on the rating plate. The basic type IM B3, IM B5 or IM B14 is stamped as standard on the rating plate. If mounted in a different position, the position must be specified to ensure that the condensation drainage holes are positioned correctly.

Selection and ordering data for 8-pole IE3 efficiency class motors

Operating values at rated output													Cast-iron series		m _{IM B3}	GD ² of Rotor	Torque class				
P _{rated} 50 Hz	Frame size	n _{rated} 50 Hz	T _{rated} 50 Hz	IE class	η _{rated} 50 Hz, 4/4	η _{rated} 50 Hz, 3/4	η _{rated} 50 Hz, 2/4	cos φ _{rated} 50 Hz, 4/4	I _{rated} 50 Hz, 415 V	T _{LR} T _{rated} 50 Hz	I _{LR} I _{rated} 50 Hz	T _g T _{rated} 50 Hz	1LE7503 IE3 version Article No.								
kW	FS	rpm	kgfm	50 Hz	%	%	%		A					kg	kgfm ²	CL					
<ul style="list-style-type: none"> Cooling: self-ventilated (IC411) Efficiency: IE3 Premium Efficiency, service factor (SF) 1.15 Insulation: thermal class 155 (temperature class F), IP55 degree of protection, utilization in accordance with thermal class 130 (temperature class B) 																					
8-pole: 750 rpm at 50 Hz																					
0.12	71	672	0.17	IE3	50.7	50.7	47.7	0.58	0.57	2.2	3.6	2.5	1LE7503-0CD3	■	■	■	■	■	12	0.0039	13
0.18	80	690	0.25	IE3	58.7	58.7	54.0	0.57	0.75	1.7	3.6	2.0	1LE7503-0DD2	■	■	■	■	■	17	0.0074	10
0.25	80	690	0.35	IE3	64.1	64.1	60.0	0.57	0.95	1.7	3.5	2.0	1LE7503-0DD3	■	■	■	■	■	25	0.0106	10
0.37	90 S	715	0.50	IE3	69.3	67.0	60.0	0.55	1.4	2.0	4.0	2.4	1LE7503-0ED0	■	■	■	■	■	27	0.0137	10
0.55	90 L	710	0.75	IE3	73.0	71.5	66.0	0.55	1.9	2.0	4.0	2.4	1LE7503-0ED4	■	■	■	■	■	29	0.0188	10
0.75	100 L	705	1.0	IE3	75.0	71.0	66.0	0.59	2.4	1.7	4.0	2.2	1LE7503-1AD4	■	■	■	■	■	32	0.0252	13
1.1	100 L	705	1.5	IE3	77.7	74.7	70.7	0.60	3.3	1.5	4.0	2.0	1LE7503-1AD5	■	■	■	■	■	37	0.0402	10
1.5	112 M	704	2.1	IE3	79.7	79.7	75.7	0.64	4.1	1.7	4.0	2.3	1LE7503-1BD2	■	■	■	■	■	50	0.0543	13
2.2	132 S	720	3.0	IE3	81.9	81.9	81.9	0.61	6.1	1.5	4.5	2.3	1LE7503-1CD0	■	■	■	■	■	60	0.0915	10
3.7	160 M	726	5.0	IE3	84.5	84.5	84.0	0.63	9.7	2.1	5.0	2.4	1LE7503-1DD2	■	■	■	■	■	120	0.3600	13
5.5	160 M	726	7.4	IE3	86.2	86.2	85.0	0.64	14	2.0	5.0	2.3	1LE7503-1DD3	■	■	■	■	■	137	0.4280	10
7.5	160 L	724	10	IE3	87.3	86.0	85.0	0.63	19	2.0	5.0	2.3	1LE7503-1DD4	■	■	■	■	■	140	0.4960	10
11	180 L	724	15	IE3	88.6	88.6	88.0	0.73	24	2.3	5.1	2.4	1LE7503-1ED4	■	■	■	■	■	165	1.0680	13
15	200 L	726	20	IE3	89.6	89.6	89.0	0.73	32	3.0	6.5	3.5	1LE7503-2AD5	■	■	■	■	■	235	1.6800	16
18.5	225 S	732	25	IE3	90.1	90.1	90.0	0.74	39	2.6	6.0	2.7	1LE7503-2BD0	■	■	■	■	■	325	2.0000	16
22	225 M	732	29	IE3	90.6	90.6	90.0	0.75	45	2.7	6.0	2.8	1LE7503-2BD2	■	■	■	■	■	395	2.7632	16
30	250 M	734	40	IE3	91.5	92.1	91.4	0.77	59	2.4	6.8	3.0	1LE7503-2CD2	■	■	■	■	■	380	3.68	16
37	280 S	736	49	IE3	91.8	92.5	91.7	0.79	71	2.1	6.0	2.4	1LE7503-2DD0	■	■	■	■	■	565	4.74	13
45	280 M	737	59	IE3	92.2	92.8	92.1	0.79	86	2.3	6.0	2.5	1LE7503-2DD2	■	■	■	■	■	570	5.83	16
55	315 S	740	72	IE3	93.0	93.2	92.8	0.79	104	2.0	5.5	2.6	1LE7503-3AD0	■	■	■	■	■	690	8.38	13
75	315 M	740	99	IE3	93.6	93.6	93.1	0.80	139	2.3	6.8	3.1	1LE7503-3AD2	■	■	■	■	■	730	13.44	16
90	315 L	739	119	IE3	93.9	94.2	93.8	0.80	167	2.2	6.0	2.8	1LE7503-3AD4	■	■	■	■	■	900	13.44	13
110	315 L	740	145	IE3	94.4	94.6	94.3	0.79	205	2.5	6.0	3.1	1LE7503-3AD5	■	■	■	■	■	1100	16.95	16
Voltages²⁾				No. of poles	Frame size	Motor type	Version						Order code(s)								
50 Hz	240 VΔ/415 VY	8	71 M ... 112M	1LE7503-0C ... -1B	Standard	2	3						-								
50 Hz	415 VΔ	8	132S ... 315 L	1LE7503-1C ... -3A	Standard	3	5						-								
For other voltages ¹⁾ and more information, code letters and descriptions, please refer Page 37																					
Types of construction				No. of poles	Frame size	Motor type	Version						Order code(s)								
Without flange	IM B3 ³⁾	8	71 M ... 315 L	1LE7503-0C ... -3A	Standard						A	-									
With flange	IM B5 ³⁾	8	71 M ... 315 M	1LE7503-0C ... -3A	With additional charge						F	-									
Further types of construction and more information, code letters and descriptions, please refer Page 37																					
Motor protection				Line	No. of poles	Frame size	Motor type	Version						Order code(s)							
Without		8	71 M ... 315 L	1LE7503-0C ... -3A	Standard						A	-									
Further motor protection and more information, code letters and descriptions, please refer Page 38																					
Terminal box position				No. of poles	Frame size	Motor type	Version						Order code(s)								
Terminal box at top		8	71 M ... 315 L	1LE7503-0C ... -3A	Standard						4	-									
Further terminal box positions and more information, code letters and descriptions, please refer Page 38																					

1) Operating values at rated output for 60Hz are stored in the Drive Technology (DT) configurator.
 2) Parallel supply lines are required in the case of connection to ≤ 240V. For frame size 315 with connection to ≤ 240V, due to the high current, a drilled, removable entry plate (Order code R52) or a larger terminal box (Order code R50) can be used. Order codes R52 and R50 alter the motor dimensions.

3) Types derived from IM B3 (IM B6/7/8, IM V6 and IM V5), from IM B5 (IM V3 and IM V1) and from IM B14 (IM V19 and IM V18) are possible, provided that no requirement exists for stamping of the type on the rating plate. The basic type IM B3, IM B5 or IM B14 is stamped as standard on the rating plate. If mounted in a different position, the position must be specified to ensure that the condensation drainage holes are positioned correctly.

Selection and ordering data for 2pole IE4 efficiency class motors

Operating values at rated output												Cast-iron series		m _{IM B3}	GD ² of Rotor	Torque class
P _{rated}	Frame size	n _{rated}	T _{rated}	IE class	η _{rated}	η _{rated}	η _{rated}	cos φ _{rated}	I _{rated}	T _{LR}	I _{LR}	T _g	1LE7504 IE4 version			
50 Hz		50 Hz	50 Hz		50 Hz, 4/4	50 Hz, 3/4	50 Hz, 2/4	50 Hz, 4/4	50 Hz, 415 V	T _{rated} , 50 Hz	I _{rated} , 50 Hz	T _{rated} , 50 Hz				
kW	FS	rpm	kgfm	50 Hz	%	%	%		A							
<ul style="list-style-type: none"> Cooling: self-ventilated (IC411) Efficiency: IE4 Super Premium Efficiency, service factor (SF) 1.15 Insulation: thermal class 155 (temperature class F), IP55 degree of protection, utilization in accordance with thermal class 130 (temperature class B) 																
2-pole: 3000 rpm at 50 Hz																
22	180M	2952	7.3	IE4	94.0	94.4	94.1	0.89	37	3.2	8.3	4.6	1LE7504-21EA2	- - ■ ■ ■ ■ ■	175	0.35
30	200 L	2966	9.9	IE4	94.5	94.6	93.8	0.83	53	3.1	8.5	4.4	1LE7504-2AA4	- - ■ ■ ■ ■ ■	237	0.56
37	200 L	2965	12	IE4	94.8	95.1	94.4	0.82	66	3.7	8.9	4.0	1LE7504-2AA5	- - ■ ■ ■ ■ ■	293	0.73
45	225M	2967	15	IE4	95	95.2	94.6	0.88	75	3.1	8.4	3.6	1LE7504-2BA2	- - ■ ■ ■ ■ ■	360	1.05
55	250 M	2979	18	IE4	95.3	95.5	95.4	0.89	90	3.5	8.9	4.0	1LE7504-2CA2	- - ■ ■ ■ ■ ■	516	2.52
75	280 S	2978	25	IE4	95.6	95.6	95.1	0.89	123	2.9	8.2	3.0	1LE7504-2DA0	- - ■ ■ ■ ■ ■	579	3.54
90	280 M	2979	29	IE4	95.8	95.8	95.1	0.88	149	3.5	8.5	4.8	1LE7504-2DA2	- - ■ ■ ■ ■ ■	641	3.84
110	315 S	2984	36	IE4	96.0	96.0	95.4	0.91	175	2.7	8.5	3.6	1LE7504-3AA0	- - ■ ■ ■ ■ ■	964	6.79
132	315 M	2983	43	IE4	96.2	96.4	96.2	0.91	210	2.9	8.7	3.8	1LE7504-3AA2	- - ■ ■ ■ ■ ■	979	7.32
160	315 L	2988	52	IE4	96.3	96.2	95.6	0.91	254	3.7	8.9	4.0	1LE7504-3AA4	- - ■ ■ ■ ■ ■	1169	9.52
200	315 L	2987	65	IE4	96.5	96.5	95.8	0.92	313	3.2	8.9	4.0	1LE7504-3AA6	- - ■ ■ ■ ■ ■	1227	10.45
Voltages ²⁾				No. of poles	Frame size	Motor type	Version	Order code(s)								
50 Hz	415 VΔ			2	250 M... 315 L	1LE7504-2C ... -3A	Standard		3		5					
For other voltages ¹⁾ and more information, code letters and descriptions, please refer Page 37																
Types of construction			No. of poles	Frame size	Motor type	Version	Order code(s)									
Without flange		IM B3 ³⁾	2	250 M ... 315 L	1LE7504-2C ... -3A	Standard						A				
With flange		IM B5 ³⁾	2	250 M ... 315 M	1LE7504-2C ... -3A	With additional charge						F				
Further types of construction and more information, code letters and descriptions, please refer Page 37																
Motor protection			Line	No. of poles	Frame size	Motor type	Version	Order code(s)								
Without			2	250 M ... 315 L	1LE7504-2C ... -3A	Standard							A			
Further motor protection and more information, code letters and descriptions, please refer Page 38																
Terminal box position			No. of poles	Frame size	Motor type	Version	Order code(s)									
Terminal box at top			2	250 M ... 315 L	1LE7504-2C ... -3A	Standard								4		
Further terminal box positions and more information, code letters and descriptions, please refer Page 38																

1) Operating values at rated output for 60Hz are stored in the Drive Technology (DT) configurator.
 2) Parallel supply lines are required in the case of connection to ≤ 240V. For frame size 315 with connection to ≤ 240V, due to the high current, a drilled, removable entry plate (Order code R52) or a larger terminal box (Order code R50) can be used. Order codes R52 and R50 alter the motor dimensions.

3) Types derived from IM B3 (IM B6/7/8, IM V6 and IM V5), from IM B5 (IM V3 and IM V1) are possible, provided that no requirement exists for stamping of the type on the rating plate. The basic type IM B3, IM B5 is stamped as standard on the rating plate. If mounted in a different position, the position must be specified to ensure that the condensation drainage holes are positioned correctly.
 4) Please contact nearest sales office for enquiry for motors in frame size 180 to 225 in mounting construction other than IM B3.

Selection and ordering data for 4pole IE4 efficiency class motors

Operating values at rated output													Cast-iron series		m _{IM B3}	GD ² of Rotor	Torque class	
P _{rated} 50 Hz	Frame size	n _{rated} 50 Hz	T _{rated} 50 Hz	IE class	η _{rated} 50 Hz, 4/4	η _{rated} 50 Hz, 3/4	η _{rated} 50 Hz, 2/4	cos φ _{rated} 50 Hz, 4/4	I _{rated} 50 Hz, 415 V	T _{LR} / T _{rated} 50 Hz	I _{LR} / I _{rated} 50 Hz	T _g / T _{rated} 50 Hz	1LE7504 IE4 version	Article No.				kg
kW	FS	rpm	kgfm	50 Hz	%	%	%		A									
<ul style="list-style-type: none"> Cooling: self-ventilated (IC411) Efficiency: IE4 Super Premium Efficiency, service factor (SF) 1.15 Insulation: thermal class 155 (temperature class F), IP55 degree of protection, utilization in accordance with thermal class 130 (temperature class B) 																		
4-pole: 1500 rpm at 50 Hz																		
18.5	180M	1477	12	IE4	94.2	94.4	93.9	0.81	34	3.1	8.3	4.4	1LE7504-1EB2		215	0.74		
22	180L	1480	14	IE4	94.5	94.9	94.4	0.78	42	3.5	8.3	4.8	1LE7504-1EB4		268	0.92		
30	200L	1481	20	IE4	94.9	95.0	94.6	0.80	55	3.5	8.3	4.0	1LE7504-2AB5		319	1.29		
37	225S	1484	24	IE4	95.2	95.3	94.8	0.83	65	2.9	8.3	3.7	1LE7504-2BB0		387	2.36		
45	225M	1486	29	IE4	95.4	95.6	95.2	0.81	81	3.7	8.3	4.5	1LE7504-2BB2		415	2.74		
55	250 M	1485	36	IE4	95.7	95.7	95.5	0.85	94	3.4	8.3	4.0	1LE7504-2CB2		520	4.50		
75	280 S	1488	49	IE4	96.0	96.1	95.7	0.83	131	3.4	8.9	4.0	1LE7504-2DB0		686	7.02		
90	280 M	1489	59	IE4	96.1	96.0	95.3	0.82	159	3.7	8.9	4.1	1LE7504-2DB2		744	8.51		
110	315 S	1490	72	IE4	96.3	96.3	95.7	0.86	185	3.4	8.9	3.8	1LE7504-3AB0		961	12.12		
132	315 M	1489	86	IE4	96.4	96.4	96.0	0.86	222	3.6	8.9	4.0	1LE7504-3AB2		1011	12.96		
160	315 L	1489	105	IE4	96.6	96.6	96.3	0.87	265	3.1	8.9	3.4	1LE7504-3AB4		1212	15.57		
200	315 L	1490	131	IE4	96.7	96.8	96.6	0.87	331	3.6	8.9	4.0	1LE7504-3AB6		1337	18.88		
Voltages ²⁾				No. of poles	Frame size	Motor type	Version	Order code(s)										
50 Hz	415 VΔ			4	250 M ... 315 L	1LE7504-2C ... -3A	Standard	2	3									
For other voltages ¹⁾ and more information, code letters and descriptions, please refer Page 37										3	5							
Types of construction				No. of poles	Frame size	Motor type	Version	Order code(s)										
Without flange		IM B3 ³⁾		4	250 M ... 315 L	1LE7504-2C ... -3A	Standard						A					
With flange		IM B5 ³⁾		4	250 M ... 315 M	1LE7504-2C ... -3A	With additional charge						F					
Further types of construction and more information, code letters and descriptions, please refer Page 37																		
Motor protection				Line	No. of poles	Frame size	Motor type	Version	Order code(s)									
Without					4	250 M ... 315 L	1LE7504-2C ... -3A	Standard						A				
Further motor protection and more information, code letters and descriptions, please refer Page 38																		
Terminal box position				No. of poles	Frame size	Motor type	Version	Order code(s)										
Terminal box at top					4	250 M ... 315 L	1LE7504-2C ... -3A	Standard							4			
Further terminal box positions and more information, code letters and descriptions, please refer Page 38																		

1) Operating values at rated output for 60Hz are stored in the Drive Technology (DT) configurator.

2) Parallel supply lines are required in the case of connection to ≤ 240V. For frame size 315 with connection to ≤ 240V, due to the high current, a drilled, removable entry plate (Order code R52) or a larger terminal box (Order code R50) can be used. Order codes R52 and R50 alter the motor dimensions.

3) Types derived from IM B3 (IM B6/7/8, IM V6 and IM V5), from IM B5 (IM V3 and IM V1) are possible, provided that no requirement exists for stamping of the type on the rating plate. The basic type IM B3, IM B5 is stamped as standard on the rating plate. If mounted in a different position, the position must be specified to ensure that the condensation drainage holes are positioned correctly.

4) Please contact nearest sales office for enquiry for motors in frame size 180 to 225 in mounting construction other than IM B3.

Selection and ordering data for 6pole IE4 efficiency class motors

















Operating values at rated output													Cast-iron series				
P_{rated} 50 Hz	Frame size	n_{rated} 50 Hz	T_{rated} 50 Hz	IE class	η_{rated} 50 Hz, 4/4	η_{rated} 50 Hz, 3/4	η_{rated} 50 Hz, 2/4	$\cos\phi_{rated}$ 50 Hz, 4/4	I_{rated} 50 Hz, 415 V	T_{LR} T_{rated} 50 Hz	I_{LR} I_{rated} 50 Hz	T_g T_{rated} 50 Hz	1LE7504 IE4 version Article No.	$m_{IM\ B3}$	GD ² of Rotor	Torque class	
kW	FS	rpm	kgfm	50 Hz	%	%	%		A					kg	kgfm ²	CL	
<ul style="list-style-type: none"> Cooling: self-ventilated (IC411) Efficiency: IE4 Super Premium Efficiency, service factor (SF) 1.15 Insulation: thermal class 155 (temperature class F), IP55 degree of protection, utilization in accordance with thermal class 130 (temperature class B) 																	
6-pole: 1000 rpm at 50 Hz																	
37	250 M	986	37	IE4	93.6	94.0	93.6	0.83	66	3.2	7.5	4.0	1LE7504-2CC2	■ - ■ ■ ■ ■ ■	410	5.51	
45	280 S	988	44	IE4	93.8	94.2	93.6	0.82	81	2.7	7.3	3.0	1LE7504-2DC0	■ - ■ ■ ■ ■ ■	555	7.81	
55	280 M	988	54	IE4	94.1	94.5	94.1	0.82	99	3.0	7.5	3.0	1LE7504-2DC2	■ - ■ ■ ■ ■ ■	560	9.88	
75	315 S	991	74	IE4	95.1	95.3	95.0	0.82	134	3.1	7.1	3.1	1LE7504-3AC0	■ - ■ ■ ■ ■ ■	760	15.08	
90	315 M	990	89	IE4	95.2	95.5	95.1	0.84	157	2.6	7.0	2.9	1LE7504-3AC2	■ - ■ ■ ■ ■ ■	850	16.78	
110	315 L	991	108	IE4	95.6	95.7	95.5	0.85	188	3.0	7.5	3.2	1LE7504-3AC4	■ - ■ ■ ■ ■ ■	1020	18.59	
132	315 L	990	130	IE4	95.8	95.9	95.7	0.86	223	3.0	7.5	3.3	1LE7504-3AC6	■ - ■ ■ ■ ■ ■	1050	19.44	
Voltagess²⁾				No. of poles	Frame size		Motor type		Version				Order code(s)				
50 Hz 415 VΔ				6	250 M ... 315 L		1LE7504-2C ... -3A		Standard				2	3			
For other voltages ¹⁾ and more information, code letters and descriptions, please refer Page 37													3	5	-		
Types of construction				No. of poles	Frame size		Motor type		Version				Order code(s)				
Without flange		IM B3 ³⁾		6	250 M ... 315 L		1LE7504-2C ... -3A		Standard				A		-		
With flange		IM B5 ³⁾		6	250 M ... 315 M		1LE7504-2C ... -3A		With additional charge				F		-		
Further types of construction and more information, code letters and descriptions, please refer Page 37													■		...		
Motor protection				Line	No. of poles	Frame size		Motor type		Version				Order code(s)			
Without					6	250 M ... 315 L		1LE7504-2C ... -3A		Standard				A		-	
Further motor protection and more information, code letters and descriptions, please refer Page 38														■		...	
Terminal box position				No. of poles	Frame size		Motor type		Version				Order code(s)				
Terminal box at top				6	250 M ... 315 L		1LE7504-2C ... -3A		Standard				4		-		
Further terminal box positions and more information, code letters and descriptions, please refer Page 38													■		...		

1) Operating values at rated output for 60Hz are stored in the Drive Technology (DT) configurator.

2) Parallel supply lines are required in the case of connection to ≤ 240V. For frame size 315 with connection to ≤ 240V, due to the high current, a drilled, removable entry plate (Order code R52) or a larger terminal box (Order code R50) can be used. Order codes R52 and R50 alter the motor dimensions.

3) Types derived from IM B3 (IM B6/7/8, IM V6 and IM V5), from IM B5 (IM V3 and IM V1) are possible, provided that no requirement exists for stamping of the type on the rating plate. The basic type IM B3, IM B5 is stamped as standard on the rating plate. If mounted in a different position, the position must be specified to ensure that the condensation drainage holes are positioned correctly.

MLFB Position 1LE7503-□□□	Voltage code	Construction code	Winding Protection code	Terminal Box code	Frame size												
	12th & 13th	14th	15th	16th	71	80	90	100	112	132	160	180	200	225	250	280	315
	■-□□□	□-□□□	□-□□□	□-□□□													
Voltage																	
50Hz, 415VΔ [#]	3-5				<input type="checkbox"/>	<input type="checkbox"/>	<input type="checkbox"/>	<input type="checkbox"/>	<input type="checkbox"/>	<input type="checkbox"/>	<input type="checkbox"/>	<input type="checkbox"/>	<input type="checkbox"/>	<input type="checkbox"/>	<input type="checkbox"/>	<input type="checkbox"/>	<input type="checkbox"/>
50Hz, 240VΔ/415VY [#]	2-3				<input type="checkbox"/>	<input type="checkbox"/>	<input type="checkbox"/>	<input type="checkbox"/>	<input type="checkbox"/>	<input type="checkbox"/>	<input type="checkbox"/>	<input type="checkbox"/>	<input type="checkbox"/>	<input type="checkbox"/>	<input type="checkbox"/>	<input type="checkbox"/>	<input type="checkbox"/>
50Hz, 220VΔ	2-1				<input checked="" type="checkbox"/>	<input checked="" type="checkbox"/>	<input checked="" type="checkbox"/>	<input checked="" type="checkbox"/>	<input checked="" type="checkbox"/>	<input checked="" type="checkbox"/>	<input checked="" type="checkbox"/>	<input checked="" type="checkbox"/>	<input checked="" type="checkbox"/>	<input checked="" type="checkbox"/>	<input checked="" type="checkbox"/>	<input checked="" type="checkbox"/>	<input checked="" type="checkbox"/>
50Hz, 230VΔ	2-2				<input checked="" type="checkbox"/>	<input checked="" type="checkbox"/>	<input checked="" type="checkbox"/>	<input checked="" type="checkbox"/>	<input checked="" type="checkbox"/>	<input checked="" type="checkbox"/>	<input checked="" type="checkbox"/>	<input checked="" type="checkbox"/>	<input checked="" type="checkbox"/>	<input checked="" type="checkbox"/>	<input checked="" type="checkbox"/>	<input checked="" type="checkbox"/>	<input checked="" type="checkbox"/>
50Hz, 360VΔ [®]	9-0				<input checked="" type="checkbox"/>	<input checked="" type="checkbox"/>	<input checked="" type="checkbox"/>	<input checked="" type="checkbox"/>	<input checked="" type="checkbox"/>	<input checked="" type="checkbox"/>	<input checked="" type="checkbox"/>	<input checked="" type="checkbox"/>	<input checked="" type="checkbox"/>	<input checked="" type="checkbox"/>	<input checked="" type="checkbox"/>	<input checked="" type="checkbox"/>	<input checked="" type="checkbox"/>
50Hz, 380VΔ	3-3				<input checked="" type="checkbox"/>	<input checked="" type="checkbox"/>	<input checked="" type="checkbox"/>	<input checked="" type="checkbox"/>	<input checked="" type="checkbox"/>	<input checked="" type="checkbox"/>	<input checked="" type="checkbox"/>	<input checked="" type="checkbox"/>	<input checked="" type="checkbox"/>	<input checked="" type="checkbox"/>	<input checked="" type="checkbox"/>	<input checked="" type="checkbox"/>	<input checked="" type="checkbox"/>
50Hz, 400VΔ	3-4				<input checked="" type="checkbox"/>	<input checked="" type="checkbox"/>	<input checked="" type="checkbox"/>	<input checked="" type="checkbox"/>	<input checked="" type="checkbox"/>	<input checked="" type="checkbox"/>	<input checked="" type="checkbox"/>	<input checked="" type="checkbox"/>	<input checked="" type="checkbox"/>	<input checked="" type="checkbox"/>	<input checked="" type="checkbox"/>	<input checked="" type="checkbox"/>	<input checked="" type="checkbox"/>
50Hz, 440VΔ [®]	9-0				<input checked="" type="checkbox"/>	<input checked="" type="checkbox"/>	<input checked="" type="checkbox"/>	<input checked="" type="checkbox"/>	<input checked="" type="checkbox"/>	<input checked="" type="checkbox"/>	<input checked="" type="checkbox"/>	<input checked="" type="checkbox"/>	<input checked="" type="checkbox"/>	<input checked="" type="checkbox"/>	<input checked="" type="checkbox"/>	<input checked="" type="checkbox"/>	<input checked="" type="checkbox"/>
50Hz, 460VΔ [®]	9-0				<input checked="" type="checkbox"/>	<input checked="" type="checkbox"/>	<input checked="" type="checkbox"/>	<input checked="" type="checkbox"/>	<input checked="" type="checkbox"/>	<input checked="" type="checkbox"/>	<input checked="" type="checkbox"/>	<input checked="" type="checkbox"/>	<input checked="" type="checkbox"/>	<input checked="" type="checkbox"/>	<input checked="" type="checkbox"/>	<input checked="" type="checkbox"/>	<input checked="" type="checkbox"/>
50Hz, 480VΔ [®]	9-0				on enquiry												
50Hz, 500VΔ [®]	4-0															<input checked="" type="checkbox"/>	<input checked="" type="checkbox"/>
Voltage other than above &/or frequency other than 50Hz	Contact Sales office																

Type of Construction																	
	IMB3	A	<input type="checkbox"/>	<input type="checkbox"/>	<input type="checkbox"/>	<input type="checkbox"/>	<input type="checkbox"/>	<input type="checkbox"/>	<input type="checkbox"/>	<input type="checkbox"/>	<input type="checkbox"/>	<input type="checkbox"/>	<input type="checkbox"/>	<input type="checkbox"/>	<input type="checkbox"/>	<input type="checkbox"/>	<input type="checkbox"/>
	IMV5	C	<input type="checkbox"/>	<input type="checkbox"/>	<input type="checkbox"/>	<input type="checkbox"/>	<input type="checkbox"/>	<input type="checkbox"/>	<input type="checkbox"/>	<input type="checkbox"/>	<input type="checkbox"/>	<input type="checkbox"/>	<input type="checkbox"/>	<input type="checkbox"/>	<input type="checkbox"/>	<input type="checkbox"/>	<input type="checkbox"/>
	IMV6	D	<input type="checkbox"/>	<input type="checkbox"/>	<input type="checkbox"/>	<input type="checkbox"/>	<input type="checkbox"/>	<input type="checkbox"/>	<input type="checkbox"/>	<input type="checkbox"/>	<input type="checkbox"/>	<input type="checkbox"/>	<input type="checkbox"/>	<input type="checkbox"/>	<input type="checkbox"/>	<input type="checkbox"/>	<input type="checkbox"/>
	IMV1	G	<input checked="" type="checkbox"/>	<input checked="" type="checkbox"/>	<input checked="" type="checkbox"/>	<input checked="" type="checkbox"/>	<input checked="" type="checkbox"/>	<input checked="" type="checkbox"/>	<input checked="" type="checkbox"/>	<input checked="" type="checkbox"/>	<input checked="" type="checkbox"/>	<input checked="" type="checkbox"/>	<input checked="" type="checkbox"/>	<input checked="" type="checkbox"/>	<input checked="" type="checkbox"/>	<input checked="" type="checkbox"/>	<input checked="" type="checkbox"/>
	IMV3 [^]	H	<input checked="" type="checkbox"/>	<input checked="" type="checkbox"/>	<input checked="" type="checkbox"/>	<input checked="" type="checkbox"/>	<input checked="" type="checkbox"/>	<input checked="" type="checkbox"/>	<input checked="" type="checkbox"/>	<input checked="" type="checkbox"/>	<input checked="" type="checkbox"/>	<input checked="" type="checkbox"/>	<input checked="" type="checkbox"/>	<input checked="" type="checkbox"/>	<input checked="" type="checkbox"/>	<input checked="" type="checkbox"/>	<input checked="" type="checkbox"/>
	IMB5 [^]	F	<input checked="" type="checkbox"/>	<input checked="" type="checkbox"/>	<input checked="" type="checkbox"/>	<input checked="" type="checkbox"/>	<input checked="" type="checkbox"/>	<input checked="" type="checkbox"/>	<input checked="" type="checkbox"/>	<input checked="" type="checkbox"/>	<input checked="" type="checkbox"/>	<input checked="" type="checkbox"/>	<input checked="" type="checkbox"/>	<input checked="" type="checkbox"/>	<input checked="" type="checkbox"/>	<input checked="" type="checkbox"/>	<input checked="" type="checkbox"/>
	IMB14	K	<input checked="" type="checkbox"/>	<input checked="" type="checkbox"/>	<input checked="" type="checkbox"/>	<input checked="" type="checkbox"/>	<input checked="" type="checkbox"/>	<input checked="" type="checkbox"/>	Not Available								
	IMV18	M	<input checked="" type="checkbox"/>	<input checked="" type="checkbox"/>	<input checked="" type="checkbox"/>	<input checked="" type="checkbox"/>	<input checked="" type="checkbox"/>	<input checked="" type="checkbox"/>	Not Available								
	IMV19	L	<input checked="" type="checkbox"/>	<input checked="" type="checkbox"/>	<input checked="" type="checkbox"/>	<input checked="" type="checkbox"/>	<input checked="" type="checkbox"/>	<input checked="" type="checkbox"/>	Not Available								
	IMB35	J	<input checked="" type="checkbox"/>	<input checked="" type="checkbox"/>	<input checked="" type="checkbox"/>	<input checked="" type="checkbox"/>	<input checked="" type="checkbox"/>	<input checked="" type="checkbox"/>	<input checked="" type="checkbox"/>	<input checked="" type="checkbox"/>	<input checked="" type="checkbox"/>	<input checked="" type="checkbox"/>	<input checked="" type="checkbox"/>	<input checked="" type="checkbox"/>	<input checked="" type="checkbox"/>	<input checked="" type="checkbox"/>	<input checked="" type="checkbox"/>
	IMB34	N	<input checked="" type="checkbox"/>	<input checked="" type="checkbox"/>	<input checked="" type="checkbox"/>	<input checked="" type="checkbox"/>	<input checked="" type="checkbox"/>	<input checked="" type="checkbox"/>	Not Available								
	IMV36 ¹	Y	<input checked="" type="checkbox"/>	<input checked="" type="checkbox"/>	<input checked="" type="checkbox"/>	<input checked="" type="checkbox"/>	<input checked="" type="checkbox"/>	<input checked="" type="checkbox"/>	<input checked="" type="checkbox"/>	<input checked="" type="checkbox"/>	<input checked="" type="checkbox"/>	<input checked="" type="checkbox"/>	<input checked="" type="checkbox"/>	<input checked="" type="checkbox"/>	<input checked="" type="checkbox"/>	<input checked="" type="checkbox"/>	<input checked="" type="checkbox"/>
	IMB6	T	<input type="checkbox"/>	<input type="checkbox"/>	<input type="checkbox"/>	<input type="checkbox"/>	<input type="checkbox"/>	<input type="checkbox"/>	<input type="checkbox"/>	<input type="checkbox"/>	<input type="checkbox"/>	<input type="checkbox"/>	<input type="checkbox"/>	<input type="checkbox"/>	<input type="checkbox"/>	<input type="checkbox"/>	<input type="checkbox"/>
	IMB7	U	<input type="checkbox"/>	<input type="checkbox"/>	<input type="checkbox"/>	<input type="checkbox"/>	<input type="checkbox"/>	<input type="checkbox"/>	<input type="checkbox"/>	<input type="checkbox"/>	<input type="checkbox"/>	<input type="checkbox"/>	<input type="checkbox"/>	<input type="checkbox"/>	<input type="checkbox"/>	<input type="checkbox"/>	<input type="checkbox"/>
	IMB8	V	<input type="checkbox"/>	<input type="checkbox"/>	<input type="checkbox"/>	<input type="checkbox"/>	<input type="checkbox"/>	<input type="checkbox"/>	<input type="checkbox"/>	<input type="checkbox"/>	<input type="checkbox"/>	<input type="checkbox"/>	<input type="checkbox"/>	<input type="checkbox"/>	<input type="checkbox"/>	<input type="checkbox"/>	<input type="checkbox"/>
	IMV15	W	<input checked="" type="checkbox"/>	<input checked="" type="checkbox"/>	<input checked="" type="checkbox"/>	<input checked="" type="checkbox"/>	<input checked="" type="checkbox"/>	<input checked="" type="checkbox"/>	<input checked="" type="checkbox"/>	<input checked="" type="checkbox"/>	<input checked="" type="checkbox"/>	<input checked="" type="checkbox"/>	<input checked="" type="checkbox"/>	<input checked="" type="checkbox"/>	<input checked="" type="checkbox"/>	<input checked="" type="checkbox"/>	<input checked="" type="checkbox"/>

- Standard Version
- Without additional charges.
- At an extra price

	MLFB: 15th	Z Code if any	Frame size														
			71	80	90	100	112	132	160	180	200	225	250	280	315		
Winding Protection																	
Without protection	A		<input type="checkbox"/>	<input type="checkbox"/>	<input type="checkbox"/>	<input type="checkbox"/>	<input type="checkbox"/>	<input type="checkbox"/>	<input type="checkbox"/>	<input type="checkbox"/>	<input type="checkbox"/>	<input type="checkbox"/>	<input type="checkbox"/>	<input type="checkbox"/>	<input type="checkbox"/>		
3x PTC thermistors for tripping (Class F)	B		✓	✓	✓	✓	✓	✓	✓	✓	✓	✓	✓	✓	✓		
6x PTC thermistors for tripping (Class F)	B	Q11	✓	✓	✓	✓	✓	✓	✓	✓	✓	✓	✓	✓	✓		
6x PTC thermistors - 3x for alarm and 3x for tripping (Class F)	C		✓	✓	✓	✓	✓	✓	✓	✓	✓	✓	✓	✓	✓		
3x PTC thermistors for tripping (Class B)	B	Q90	✓	✓	✓	✓	✓	✓	✓	✓	✓	✓	✓	✓	✓		
6x PTC thermistors for tripping (Class B)	B	Q11+Q90	✓	✓	✓	✓	✓	✓	✓	✓	✓	✓	✓	✓	✓		
6x PTC thermistors - 3x for alarm and 3x for tripping (Class B)	C	Q90	✓	✓	✓	✓	✓	✓	✓	✓	✓	✓	✓	✓	✓		
3x PT100 resistance thermometers in stator winding - 2 wire	H		✓	✓	✓	✓	✓	✓	✓	✓	✓	✓	✓	✓	✓		
6x PT100 resistance thermometers in stator winding - 2 wire	J		On Enquiry							✓	✓	✓	✓	✓	✓	✓	
Embedded temperature sensor- PT1000	K		Not Available							✓	✓	✓	✓	✓	✓	✓	
2x Embedded temperature sensor- PT1000	L		Not Available							✓	✓	✓	✓	✓	✓	✓	
3x PT100 resistance thermometers in stator winding - 3 wire	Z	Q1B	Not Available							✓	✓	✓	✓	✓	✓	✓	
6x PT100 resistance thermometers in stator winding - 3 wire	Z	Q2B	Not Available							✓	✓	✓	✓	✓	✓	✓	
12x PT100 resistance thermometers in stator winding - 3 wire	Z	Q2B+Q66	Not Available												✓		
3x Bi-metallic sensors for trip operation (Thermostats)	Z	Q3A	✓	✓	✓	✓	✓	✓	✓	✓	✓	✓	✓	✓	✓		
6x Bi-metallic sensors (3x for alarm, 3x for tripping) (Thermostats)	Z	Q9A	On Enquiry														
3x Bi-metallic sensors (opener) for trip operation (Thermostats) - additional		Q31 ²	Not Available							On Enquiry							
6x Bi-metallic sensors (opener) for trip operation (Thermostats) - additional		Q32 ²	Not Available				On Enquiry										
3x PT100 resistance thermometers in stator winding - 3 wire (additional)		Q65 ²	Not Available							On Enquiry							
6x PT100 resistance thermometers in stator winding - 3 wire (additional) - [In addition to Q2B]		Q66 ²	On Enquiry												✓		
Terminal Box Position																	
Terminal Box on TOP	4		<input type="checkbox"/>	<input type="checkbox"/>	<input type="checkbox"/>	<input type="checkbox"/>	<input type="checkbox"/>	<input type="checkbox"/>	<input type="checkbox"/>	<input type="checkbox"/>	<input type="checkbox"/>	<input type="checkbox"/>	<input type="checkbox"/>	<input type="checkbox"/>	<input type="checkbox"/>		
Mains Terminal box on RHS as viewed from DE	5		Not Available				✓	✓	✓	✓	✓	✓	✓	✓	✓	✓	
Mains Terminal box on LHS as viewed from DE	6		Not Available				✓	✓	✓	✓	✓	✓	✓	✓	✓	✓	

- Standard Version
- Without additional charges.
- ✓ - At an extra price

Note:

- # As an industry standard, ratings ≤1.5kW are star connected and ratings >1.5kW are delta connected.
- @ Voltage code 9-0 in position 12-13 requires additional order code M1Y along with plain text mentioning voltage & frequency.
- 1 IMV35 shall be punched when used with B59
- 2 Can not be offered when MLFB 15th digit is "A"
- ^ Except frame 315L

Price Add-ons for 1LE7

Options (Non-standard features / Accessories) - Simotics																			
Sr. No.	Description	Z- Code	Remarks	Note	Frame size														
					71	80	90	100	112	132	160	180	200	225	250	280	315		
					0C	0D	0E	1A	1B	1C	1D	1E	2A	2B	2C	2D	3A		
1	2x PT100 screw-in resistance thermometers (2 wire) for rolling-contact bearings [Simplex 2 wire type]	Q72			Not Applicable							✓	✓	✓	✓	✓	✓	✓	✓
2	2x PT100 screw-in resistance thermometers (3 wire) for rolling-contact bearings [Simplex 3 wire type]	Q67			Not Applicable							✓	✓	✓	✓	✓	✓	✓	✓
3	2x PT100 double screw-in resistance thermometers (3 wire) for rolling-contact bearings [Duplex 3 wire type]	Q68			Not Applicable							✓	✓	✓	✓	✓	✓	✓	✓
Connection and Connection Box																			
4	External Grounding (Earthing) Terminal on motor feet	H04			0	0	0	0	0	0	0	0	0	0	0	0	0	0	
5	Second external grounding (earthing) terminal on motor feet	H70			0	0	0	0	0	0	0	0	0	0	0	0	0	0	
6	Rotation of the mains terminal box through 90°, entry from DE	R10			0	0	0	0	0	0	0	0	0	0	0	0	0	0	
7	Rotation of the mains terminal box through 90°, entry from NDE	R11			0	0	0	0	0	0	0	0	0	0	0	0	0	0	
8	Rotation of mains terminal box through 180°	R12			0	0	0	0	0	0	0	0	0	0	0	0	0	0	
9	6x flying leads, 0.5 m long	R22			✓	✓	✓	✓	✓	✓	✓	✓	Not Available						
10	6x flying leads, 1.5 m long	R23			✓	✓	✓	✓	✓	✓	✓	✓	✓	✓	✓	✓	✓	✓	
11	6x flying leads, 3 m long	R24			✓	✓	✓	✓	✓	✓	✓	✓	✓	✓	✓	✓	✓	✓	
12	Reducer	R30			Not Available							✓	✓	✓	✓	✓	✓	✓	
13	Removable cable entry plate	R52			Not Available							✓	✓	✓	✓	✓	✓	✓	
14	Undrilled removable entry plate	R53			Not Available							#	✓	✓	✓	✓	✓	✓	
15	Next larger mains terminal box	R50			✓	✓	✓	✓	✓	✓	✓	✓	✓	✓	✓	✓	✓	✓	
16	Cable end box extension	R59	Possible only in combination with R52/ R53 for frame size upto 280; R50/R52/R53 in frame size 315		Not Available							✓	✓	✓	✓	✓	✓	✓	
17	1x Cast-iron auxiliary terminal box (Small)	R62			Not Available							✓	✓	✓	✓	✓	✓	✓	
18	1x Cast-iron auxiliary terminal box (Large)	R63			Not Available							#	#	✓	✓	✓	✓		
19	2x Cast-iron auxiliary terminal box (Small)	R67			Not Available							✓	✓	✓	✓	✓	✓	✓	
20	2x Cast-iron auxiliary terminal box (Large)	R68			Not Available										✓	✓	✓		
21	Mains Terminal box - Cast Iron (where AI is a standard upto FS 132 and CR Steel as a standard for FS 160-180)	R64			✓	✓	✓	✓	✓	✓	✓	✓	0	0	0	0	0		
22	Non-standard threaded through hole (NPT or G thread)	Y61			0	0	0	0	0	0	0	0	0	0	0	0	0		
Winding & Insulation																			
23	Ambient temperature 55°C (F utilised to B limits)	N07	Only with 1LE76		0	0	0	0	0	0	0	0	0	0	0	0	0		
24	Temperature class 155 (F), utilized acc. to 155 (F), with service factor (SF)	N01			0	0	0	0	0	0	0	0	0	0	0	0	0		
25	Temperature class 155 (F), utilized acc. to 155 (F), with increased output	N02			0	0	0	0	0	0	0	0	0	0	0	0	0		
26	Temperature class 155 (F), utilized acc. to 155 (F), with increased ambient temperature	N03			0	0	0	0	0	0	0	0	0	0	0	0	0		

Notes:

- 1 Not available for IC416 cooling.
- # Only when configurable in SPC
- * Prior quotation from works necessary
- Standard Version

- 0 Without additional charges.
- ✓ At an extra price
- + Inverter suitable winding >500V :- 6th position in MLFB should be with digit

Options (Non-standard features / Accessories) - Simotics																		
Sr. No.	Description	Z- Code	Remarks	Note	Frame size													
					71	80	90	100	112	132	160	180	200	225	250	280	315	
Winding & Insulation (continued)																		
27	Temperature class 180 (H) at rated output and max. CT 60 °C	N11			On Enquiry													
28	Temperature class 180 (H) at rated output	N10			✓	✓	✓	✓	✓	✓	✓	✓	✓	✓	✓	✓	✓	
Environmental protection																		
29	Anti-corrosive treatment for winding overhang	N22			✓	✓	✓	✓	✓	✓	✓	✓	✓	✓	✓	✓	✓	
30	Increased air humidity / temperature (30g to 60g of water /m ³ of air)	N30			On Enquiry					On Enquiry				✓	✓	✓		
31	Increased air humidity / temperature (60g to 100g of water /m ³ of air)	N31			On Enquiry					On Enquiry				✓	✓	✓		
32	Sea worthy packaging	B12			✓	✓	✓	✓	✓	✓	✓	✓	✓	✓	✓	✓	✓	
Motors for Converter Fed Operation																		
33	Inverter suitable winding		For frame size 71-225 (Inverter output voltage ≤480V) For frame size 250-315 (Inverter output voltage ≤500V)		O	O	O	O	O	O	O	O	O	O	O	O	O	
34	Inverter suitable winding		For frame size 71-225 (Inverter output voltage>480 and ≤690V)+ For frame size 250-315 (Inverter output voltage>500 and ≤690V)+		On Enquiry										✓	✓	✓	
35	Insulated Bearing at NDE	L53			Not Available										✓	✓	✓	✓
36	Mounting of Separately Driven Fan	F70			Not Available					✓	✓	✓	✓	✓	✓	✓	✓	
37	Separately driven fan with non-standard voltage and/or frequency	Y81	To be ordered alongwith F70		Not Available					✓	✓	✓	✓	✓	✓	✓	✓	
Heating & Ventilation																		
38	Fan cover for textile industry (Clean Flow Fan Cowl includes Canopy)	F75			NA	✓	✓	✓	✓	✓	✓	Not Available						
39	Metal external fan (Metal Fan [no AL])	F76		1	✓	✓	✓	✓	✓	✓	✓	✓	✓	✓	✓	✓	✓	
40	Without external fan and without fan cover	F90		1	✓	✓	✓	✓	✓	✓	✓	✓	✓	✓	✓	✓	✓	
41	Fan cover with Canopy	H00			✓	✓	✓	✓	✓	✓	✓	✓	✓	✓	✓	✓	✓	
42	Anti-condensation heaters for 230 V	Q02			NA	NA	✓	✓	✓	✓	✓	✓	✓	✓	✓	✓	✓	
43	Anti-condensation heaters for 115 V	Q03			NA	NA	✓	✓	✓	✓	✓	✓	✓	✓	✓	✓	✓	
44	Anti-condensation heaters for 240 V	Q07			NA	NA	✓	✓	✓	✓	✓	✓	✓	✓	✓	✓	✓	
45	Anti-condensation heaters for 120 V	Q08			NA	NA	✓	✓	✓	✓	✓	✓	✓	✓	✓	✓	✓	
Colour & Paint Finish																		
Paint Shades (If no paint shade is selected, then RAL 7030 is the standard)																		
46	Standard Paint Shade - RAL 7030				O	O	O	O	O	O	O	O	O	O	O	O	O	
47	Standard RAL paint shades other than RAL7030	Y53	Specify RAL shade code in plain text		✓	✓	✓	✓	✓	✓	✓	✓	✓	✓	✓	✓	✓	
48	Special RAL paint shades or shades as per IS:5	Y56	Specify RAL/IS shade code in plain text		✓	✓	✓	✓	✓	✓	✓	✓	✓	✓	✓	✓	✓	

Notes: 1. Y53 or Y56 (only one at a time) can be combined with any of the paint finishes indicated in 43 to 47. Below. Just add the appropriate price from 41 or 42.
2. Some paint shades both from Y53 or Y56 are only possible with S07. Please consult sales offices for the same.

Notes:

- 1 Not available for IC416 cooling.
- # Only when configurable in SPC
- * Prior quotation from works necessary
- Standard Version

- O Without additional charges.
- ✓ At an extra price
- + Inverter suitable winding >500V :- 6th position in MLFB should be with digit

Options (Non-standard features / Accessories) - Simotics														
Sr. No.	Description	Z- Code	Remarks	Note	Frame size									
					71	80	90	100	112	132	160	180	200	225
Colour & Paint Finish (continued)														
Acrylic Paint Finish (If no paint finish is selected, Acrylic based paint finish is standard)														
49			60µ standard.		O	O	O	O	O	O	O	O	O	O
50	Epoxy based Paint - Standard paint thickness	S07+Y57(90)	DFT 90µ		✓	✓	✓	✓	✓	✓	✓	✓	✓	✓
51	Epoxy based Paint - Special paint thickness DFT 120µ	S07+Y57(120)	DFT 120µ [Y57 (120)]		✓	✓	✓	✓	✓	✓	✓	✓	✓	✓
52	Epoxy based Paint - Special paint thickness DFT 180µ	S07+Y57(180)	DFT 180µ [Y57 (180)]		✓	✓	✓	✓	✓	✓	✓	✓	✓	✓
53	Special finish for use onshore sea air resistant	S03+S06+Y57+H07	180µ [Y57(180)] 240µ [Y57(240)]	On Enquiry										
54	Special paint thickness for offshore use	S04+S06+Y57+H07	295µ [Y57(295)]	On Enquiry										
Notes:														
1. Paint thickness needs to be specified by means of plain text irrespective of whether it is standard or special.														
2. S06 - Final Coat Polyurethane is mandatory with S03 or S04. S06 is not possible to be ordered separately.														
3. H07 - Non-rusting external hardware is mandatory with S03 or S04. H07 can be separately order even without S03 or S04. The separate price for H07 is available against the option at another location.														
55	Motor supplied unpainted - only with (Red-oxide) Primer	S01			O	O	O	O	O	O	O	O	O	O
Encoders														
56	Kubler Sendix 5020 HTL Rotary Pulse encoder-10	G11			✓	✓	✓		On Enquiry				Not available	
57	Kubler Sendix 5020 TTL Rotary Pulse encoder-10	G12			✓	✓	✓		On Enquiry				Not available	
58	LL 861 900 220 rotary pulse encoder	G04			Not Available	✓	✓	✓	✓	✓	✓	✓	✓	✓
59	HOG 9 DN 1024 I rotary pulse encoder	G05			Not Available	✓	✓	✓	✓	✓	✓	✓	✓	✓
60	HOG 10 D 1024 I rotary pulse encoder	G06			Not Available	✓	✓	✓	✓	✓	✓	✓	✓	✓
61	Baumer Thalheim make ITD 40 A4 Y126 1024 encoder	G17			Not Available	✓	✓	✓	✓	✓	✓	✓	✓	✓
62	HOG 86 TP6 DN 1024 I encoder	G19			Not Available	✓	✓	✓	✓	✓	✓	✓	✓	✓
63	Prepared for mounting Baumer Thalheim make ITD 40 A4 Y126 1024 - encoder	G44			Not Available	✓	✓	✓	✓	✓	✓	✓	✓	✓
64	Prepared for mounting cylindrical shaft encoder - 16dia x 52	G45			Not Available	✓	✓	✓	✓	✓	✓	✓	✓	✓
65	Prepared for any make Cylindrical Hollow Shaft Encoder	Y71			On Enquiry									
66	Mounting of rotary pulse encoder HOG 10 DN 1024 I + FSL, (speed rpm), connection box protection against moisture	Y74			Not Available					On Enquiry				
67	Mounting of rotary pulse encoder HOG 10 DN 1024 I + FSL, (speed rpm), connection box protection against dust	Y76			Not Available					On Enquiry				
68	Mounting of rotary pulse encoder HOG 10 DN 1024 I + E SL 93, (speed rpm), connection box protection against moisture	Y79			Not Available					On Enquiry				
Brake motors														
69	Mounting of brake F01 for FS 71 to 112 in 4,6,8 pole F07 for FS 132 to 225	F01 and F07			✓	✓	✓	✓	✓	✓	✓	✓	✓	Not available
70	Brake supply voltage 24 V DC	F10			✓	✓	✓	✓	✓	✓	✓	✓	✓	Not available
71	Brake supply voltage 230 V AC, 50/60 Hz	F11			✓	✓	✓	✓	✓	✓	✓	✓	✓	Not available
72	Brake supply voltage 400 V AC, 50/60 Hz	F12			✓	✓	✓	✓	✓	✓	✓	✓	✓	Not available
73	Brake supply voltage 240 V AC, 50/60 Hz	F13			✓	✓	✓	✓	✓	✓	✓	✓	✓	Not available

Notes:

- 1 Not available for IC416 cooling.
- # Only when configurable in SPC
- * Prior quotation from works necessary
- Standard Version

- O Without additional charges.
- ✓ At an extra price
- + Inverter suitable winding >500V :- 6th position in MLFB should be with digit

Options (Non-standard features / Accessories) - Simotics																	
Sr. No.	Description	Z- Code	Remarks	Note	Frame size												
					71	80	90	100	112	132	160	180	200	225	250	280	315
Brake motors (continued)																	
74	Brake supply voltage 415 V AC, 50/60 Hz	F14			✓	✓	✓	✓	✓	✓	✓	✓	✓	Not available			
75	Mechanical manual brake release with lever (cannot be locked)	F50			0	0	0	0	0	0	0	0	0	Not available			
Mechanical Design & Degrees of Protection																	
76	Vibration proof version	H02			On Enquiry										✓	✓	✓
77	Condensation drainage holes - sealed with a plug	H03			✓	✓	✓	0	0	0	0	0	0	0	0	0	0
78	Stainless steel fasteners (external)	H07			✓	✓	✓	✓	✓	✓	✓	✓	✓	✓	✓	✓	✓
79	Mains Terminal box on NDE	H08			Not Available										On Enquiry		
80	IP65 degree of protection	H20			✓	✓	✓	✓	✓	✓	✓	✓	✓	✓	✓	✓	✓
81	IP56 degree of protection (non-heavy-sea)	H22			✓	✓	✓	✓	✓	✓	✓	✓	✓	✓	✓	✓	✓
Bearing & Lubrication																	
82	Measuring nipple for SPM shock pulse measurement for bearing inspection	Q01			Not Available			✓	✓	✓	✓	✓	✓	✓	✓	✓	✓
83	Locating bearing, DE	L20			On Enquiry												
84	Bearing design for increased cantilever forces	L22	NU (Cylindrical Roller) Brgs		Not Available					✓	✓	✓	✓	✓	✓	✓	
85	Regreasing device	L23			Not Available					✓	✓	✓	□	□	□	□	
86	Bearings reinforced at both ends for DE and NDE, bearing size 63	L25	Only where 62 series is a standard		✓	✓	✓	✓	✓	✓	□	□	□	□	□	□	
87	C4 clearance bearing at DE & NDE	L31			Not Available					On Enquiry		✓	✓	✓	✓	✓	
88	SKF bearing at DE & NDE	L32			✓	✓	✓	✓	✓	✓	✓	✓	✓	✓	✓	On Enquiry	
89	Double Sealed (ZZ) bearings (permanently lubricated) - only for ball bearings at DE & NDE	L33			□	□	□	□	□	□	□	□	□	✓	✓	✓	✓
Balance & Vibration Quality																	
90	Vibration Severity Level A				0	0	0	0	0	0	0	0	0	0	0	0	0
91	Vibration Severity Level B	L00			✓	✓	✓	✓	✓	✓	✓	✓	✓	✓	✓	✓	✓
92	Balancing without key	L01			✓	✓	✓	✓	✓	✓	✓	✓	✓	✓	✓	✓	✓
93	Full key balancing	L02			✓	✓	✓	✓	✓	✓	✓	✓	✓	✓	✓	✓	✓
Shaft & Rotor																	
94	Standard Double Shaft Extension (SDSE)	L05		1	✓	✓	✓	✓	✓	✓	✓	✓	✓	✓	✓	✓	✓
95	Shaft material - Stainless steel	L06			✓	✓	✓	✓	✓	✓	On Enquiry						
96	Non-standard cylindrical shaft extension - DE	Y58		*	✓	✓	✓	✓	✓	✓	✓	✓	✓	✓	✓	✓	✓
97	Non-standard cylindrical shaft extension - NDE	Y59		*1	✓	✓	✓	✓	✓	✓	✓	✓	✓	✓	✓	✓	✓
98	Special shaft steel:___	Y60			On Enquiry												
99	Tapered shaft extension DE	Y62			On Enquiry												
100	Tapered shaft extension NDE	Y63		*1	On Enquiry												
101	Oil Tight shaft	H23	Only for Flange motors and gear box assembly		✓	✓	✓	✓	✓	✓	✓	✓	✓	✓	✓	On Enquiry	
Rating Plate & Extra Rating Plate																	
102	Stainless steel nameplate				0	0	0	0	0	0	0	0	0	0	0	0	0
103	Direction indicating arrow - Clockwise	L10			✓	✓	✓	✓	✓	✓	✓	✓	✓	✓	✓	✓	✓
104	Direction indicating arrow - Counter-clockwise	L11			✓	✓	✓	✓	✓	✓	✓	✓	✓	✓	✓	✓	✓
105	Extra rating plate with deviating rating plate data	Y80			✓	✓	✓	✓	✓	✓	✓	✓	✓	✓	✓	✓	✓
106	Extra rating plate with identification code - Auxilliary nameplate	Y82			✓	✓	✓	✓	✓	✓	✓	✓	✓	✓	✓	✓	✓
107	Additional information on rating plate and on package label (max. of 20 characters)	Y84			✓	✓	✓	✓	✓	✓	✓	✓	✓	✓	✓	✓	✓

Notes:

- 1 Not available for IC416 cooling.
- # Only when configurable in SPC
- * Prior quotation from works necessary
- Standard Version

- 0 Without additional charges.
- ✓ At an extra price
- + Inverter suitable winding >500V :- 6th position in MLFB should be with digit

Options (Non-standard features / Accessories) - Simotics																	
Sr. No.	Description	Z- Code	Remarks	Note	Frame size												
					71	80	90	100	112	132	160	180	200	225	250	280	315
Rating Plate & Extra Rating Plate (continued)																	
108	Nameplate in accordance with IEC	B59			✓	✓	✓	✓	✓	✓	✓	✓	✓	✓	✓	✓	✓
109	Additional information on rating plate and on package label (max. of 20 characters)	Y94			Not Available						✓	✓	✓	✓	✓	✓	✓
110	Second rating plate, supplied loose	M10			✓	✓	✓	✓	✓	✓	✓	✓	✓	✓	✓	✓	✓
Testing Charges																	
111	Witnessing of Routine Test as per IS15999	B65			✓	✓	✓	✓	✓	✓	✓	✓	✓	✓	✓	✓	✓
112	Visual Inspection (Includes Dimension Measurement and paint shade and thickness)	B66			✓	✓	✓	✓	✓	✓	✓	✓	✓	✓	✓	✓	✓
113	Type test as per IS 15999	B83			✓	✓	✓	✓	✓	✓	✓	✓	✓	✓	✓	✓	✓
114	Noise measurement without spectrum analysis with acceptance	B70			On Enquiry												
115	Noise measurement with spectrum analysis with acceptance	B72			On Enquiry												

Notes:

- 1 Not available for IC416 cooling.
- # Only when configurable in SPC
- * Prior quotation from works necessary
- Standard Version

- Without additional charges.
- ✓ At an extra price
- + Inverter suitable winding >500V :- 6th position in MLFB should be with digit

Dimensional drawings

1LE7 (Frame size 71-132) IMB3-IE2

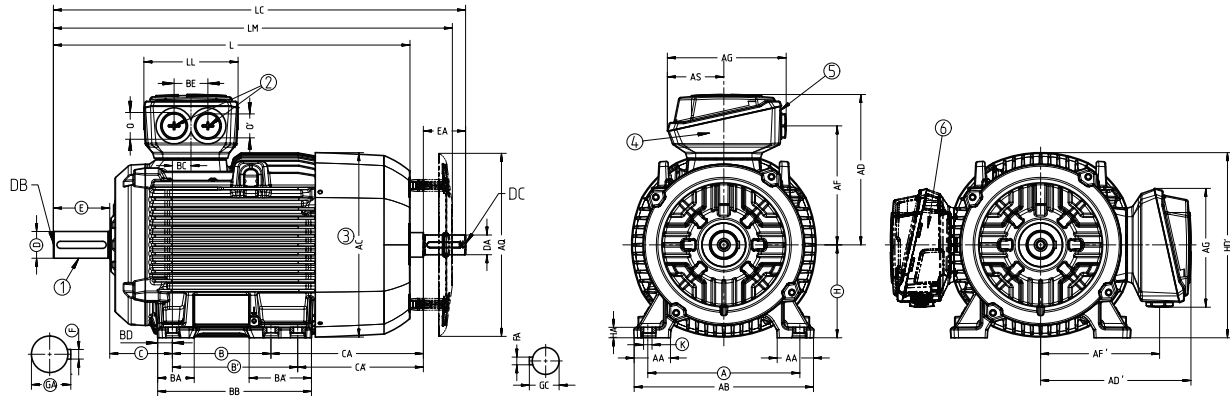

Frame size	No. of poles																				Shaft extension																							
																					Drive end					Non-drive end																		
		A	AA	AB	AC	AD	AD'	AG	AS	AQ	B	B'	BA	BA'	BB	BC	BD	BE	C	CA	CA'	H	HA	AF	AF'	HD'	K	L	LM	LC	LL	O	O'	D	DB	E	F	GA	DA	DC	EA	FA	GC	
71M	2,4,6	112	30.5	134	145	135	NA	111	47.5	125	90	NA	NA	NA	112	29	11	33	45	88	NA	71	8	102	NA	NA	7	248	280	283	89	M16	M25	14	M5	30	5	16	14	M5	30	5	16	
80M	2,4,6	125	30.5	150	162	140	NA	111	47.5	155	100	NA	NA	NA	122	22.5	11	33	50	112.5	NA	80	9	107	NA	NA	10	292	328	342.5	89	M16	M25	19	M6	40	6	21.5	19	M6	40	6	21.5	
90S ^②	2,4,6										100	-							159	-							356	392	405	89	M16	M25	24	M8	50	8	27	19	M6	40	6	21.5		
90L ^④	4 ^④	140	30.5	168	180	151	NA	111	47.5	155	-	125	36	62	148	33	11	33	56	-	134	90	11	118	NA	NA	10	396	432	445	89	M16	M25											
90L ^④	2,6																		-	174																								
100L	2 4,6	160	42	196	217	174	174	163	80.5	195	140	NA	48	48	176	37.5	18	48	63	176 141	NA	100	12	135	132	202	12	425	465	489	126			28	M10	60	8	31	24	M8	50	8	27	
112M	4,6	190	46	226	239	177	177	163	80.5	195	140	NA	48	48	176	30	18	48	70	155	NA	112	15	135	135	226	12	409	449	475	134	M32	M32	28	M10	60	8	31	24	M8	50	8	27	
132S	2,4,6										140	-								166.5	-							458	518	535.5	134													
132M	4,6	216	53	256	281	215	215	163	80.5	260	140	-	52	89	218	26.5	20	48	89	216.5	-	132	15	169	169	266	12	508	568	585.5	134			38	M12	80	10	41	28	M10	60	8	31	
132M	4,6												-	178						-	178.5							508	568	585.5														

- ① Shaft extension as per IEC:60072 / IS:1231
- ② 2 Nos. Conduit Entry as per IEC:60423 / IS:14763
- ③ Measured over bolt heads
- ④ Terminal box can be rotated in steps of 90°
- ⑤ Cable End box of Non Detachable type
- ⑥ For Terminal Box on left, view is "mirror image"
- ⑦ For 1.5 kW output
- ⑧ Eye bolt provided as lifting arrangement
- ⑨ For 7.5 kW output

Definitive Dimensions:

A, B, B', C, H, K, D, E, F, GA are binding dimensions for all standard motors.

All other dimensions are subject to change.

For valid dimensions, please contact Regional office in your region.

1LE7 (Frame size 71-132) IMB5/V1-IE2

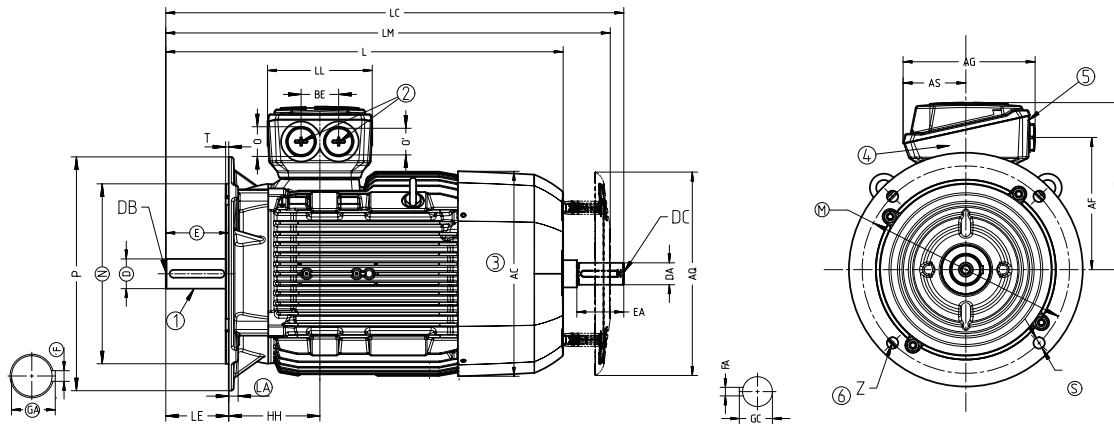

Frame size	No. of poles	AC	AD	AG	AS	AQ	LE	AF	BE	HH	L	LM	LC	LL	O	O'	Shaft extension										Flange							
																	Drive end					Non-drive end					Number	LA	M	N	P	S	T	Z
																	D	DB	E	F	GA	DA	DC	EA	FA	GC								
71M	2,4,6	145	135	111	47.5	125	30	102	33	74	248	280	283	89	M16	M25	14	M5	30	5	16	14	M5	30	5	16	F130B	9	130	110	160	10	3.5	4
80M	2,4,6	162	140	111	47.5	155	40	107	33	72.5	292	328	342.5				19	M6	40	6	21.5	19	M6	40	6	21.5	F165B	10	165	130	200	12	3.5	4
90S	2,4,6	180	151	111	47.5	155	50	118	33	89	356	392	405																					
90L	4Ⓞ										2	217	174	163	80.5	195	60	132	48	100.5	396	423	445	126	M32	28	M10	60	8	31	24	M8	50	8
90L	2,6	425	465	489	390	430	454																											
100L	4,6	217	174	163	80.5	195	60	132	48	100.5	425	465	489	134	M32	M32	28	M10	60	8	31	24	M8	50	8	27	F215B	11	215	180	250	15	4	4
112M	4,6	239	177	163	80.5	195	60	135	48	100	409	449	475																					
132S	2,4,6	281	215	163	80.5	260	80	169	48	115.5	508	568	585.5	134	M32	M32	38	M12	80	10	41	28	M10	60	8	31	F265B	12	265	230	300	15	4	4
132M	4,6										508	568	585.5																					

- ① Shaft extension as per IEC:60072 / IS:1231
- ② 2 Nos. Conduit Entry as per IEC:60423 / IS:14763
- ③ Measured over bolt heads
- ④ Terminal box can be rotated in steps of 90°
- ⑤ Cable End box of Non Detachable type
- ⑥ No. of fixing holes
- ⑦ Flange as per IEC:60072 / IS:2223
- ⑧ For 1.5 kW output
- ⑨ For 7.5 kW output

Definitive Dimensions:
A,B,B',C,H,K,D,E,F,GA are binding dimensions for all standard motors.
All other dimensions are subject to change.
For Valid dimensions, please contact Regional office in your region.

1LE7 (Frame size 71-132) IMB14-IE2

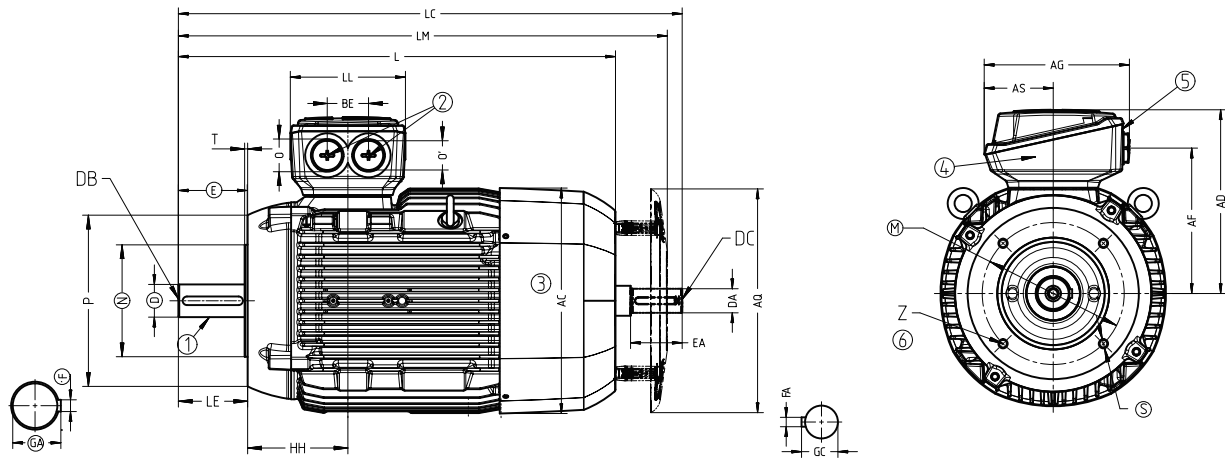

Frame size	No. of poles	AC	AD	AG	AS	AQ	AF	BE	LE	HH	L	LM	LC	LL	O	O'	Shaft extension										IM B14 Flange							
																	Drive end					Non-drive end					⌀ Number	M	N	P	S	T	Z	
																	D	DB	E	F	GA	DA	DC	EA	FA	GC								
71M	2,4,6	145	135	111	47.5	125	102	33	30	74	248	280	283	89	M16	M25	14	M5	30	5	16	14	M5	30	5	16	F85C	85	70	105	M6	2.5	4	
80M	2,4,6	162	140	111	47.5	155	107	33	40	72.5	292	328	342.5				19	M6	40	6	21.5	19	M6	40	6	21.5	F100C	100	80	120	M6	3	4	
90S	2,4,6	180	151	111	47.5	155	118	33	50	89	356	392	405				24	M8	50	8	27	19	M6	40	6	21.5	F115C	115	95	140	M8	3	4	
90L	4⊙										396	432	445				396	432	445	28	M10	60	8	31	24	M8	50	8	27	F130C	130	110	160	M8
100L	2	217	174	163	80.5	195	132	48	60	100.5	425	465	489	126	M32	M32	28	M10	60	8	31	24	M8	50	8	27	F130C	130	110	160	M8	3.5	4	
112M	4,6										390	430	454				28	M10	60	8	31	24	M8	50	8	27	F130C	130	110	160	M8	3.5	4	
132S	2,4,6	281	215	163	80.5	260	169	48	80	115.5	458	518	535.5	134	M32	M32	28	M10	60	8	31	24	M8	50	8	27	F130C	130	110	160	M8	3.5	4	
132M	2⊙										508	568	585.5				38	M12	80	10	41	28	M10	60	8	31	F165C	165	130	200	M10	3.5	4	
132M	2,4,6										508	568	585.5																					

- ① Shaft extension as per IEC:60072 / IS:1231
- ② 2 Nos. Conduit Entry as per IEC:60423 / IS:14763
- ③ Measured over bolt heads
- ④ Terminal box can be rotated in steps of 90°
- ⑤ Cable End box of Non Detachable type
- ⑥ No. of fixing holes
- ⑦ Flange as per IEC:60072 / IS:2223
- ⑧ For 1.5 kW output
- ⑨ For 7.5 kW output

Definitive Dimensions:
A,B,B',C,H,K,D,E,F,GA are binding dimensions for all standard motors.
All other dimensions are subject to change.
For Valid dimensions, please contact Regional office in your region.

1LE7 (Frame size 160-225) IMB3-IE2

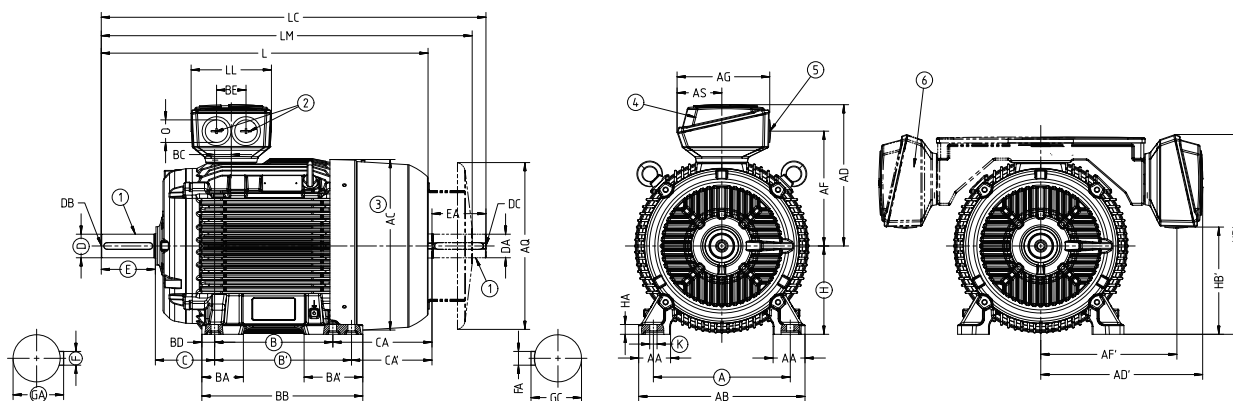

Frame size	No. of poles	A	AA	AB	AC	AD	AD'	AG	AS	AQ	B	B'	BA	BA'	BB	BC	BD	BE	C	CA	CA'	H	HA	AF	HB'	AF'	HD'	K	L	LC	LL	LM	O	Shaft extension													
																																		Drive end				Non-drive end									
																																		D	DB	E	F	GA	DA	DC	EA	FA	GC				
160M	2,4,6										210	-								192	-		18	213	179	276	367	14.5	594	730	654																
160L	2,6	254	60	300	314	267	330	190	92	260	-	254	73	117	300	37	23	60	108	-	208	160	20	213	179	276	367	14.5	654	790	165	714	M40	42	M16	110	12	45	42	M16	110	12	45				
	4																				-	148																									
180M	2,4										241	-								202	-		20	234	220	276	408	14.5	668	784	758																
180L	4	279	65	339	356	288	330	190	92	340	-	279	85	120	328	34	26	60	121	-	194	180	20	234	220	276	408	14.5	698	814	165	788	M40	48	M16	110	14	51.5	48	M16	110	14	51.5				
	6																				-	164																									
200L	2,4,6	318	70	378	396	318	363	266	112	340	305	NA	104	104	355	31	25	85	133	177	-	200	25	259	209	304	471	18.5	721	835	197	811	M50	55	M20	110	16	59	55	M20	110	16	59				
225S	4										286	-								218	-																										
	2																				-	253	225	34	282	257	304	519	18.5	818	933	197	915	M50	55	M20	110	16	59	48	M16	110	14	51.5			
225M	4	356	80	436	449	341	363	266	112	425	-	311	93	118	361	15	25	85	149	-	253	225	34	282	257	304	519	18.5	848	963		945	M50	60	M20	140	18	64	55	M20	110	16	59				
	6																				-	193																									

- ① Shaft extension as per IEC:60072 / IS:1231
- ② 2 Nos. Conduit Entry as per IEC:60423 / IS:14763
- ③ Measured over bolt heads
- ④ Terminal box can be rotated in steps of 90°
- ⑤ Cable End box of Non Detachable type
- ⑥ For Terminal Box on left, view is "mirror image"

Definitive Dimensions:
 A,B,B',C,H,K,D,E,F,GA are binding dimensions for all standard motors.
 All other dimensions are subject to change.
 For valid dimensions, please contact Regional office in your region.

1LE7 (Frame size 160-225) IMB5/IMV1-IE2

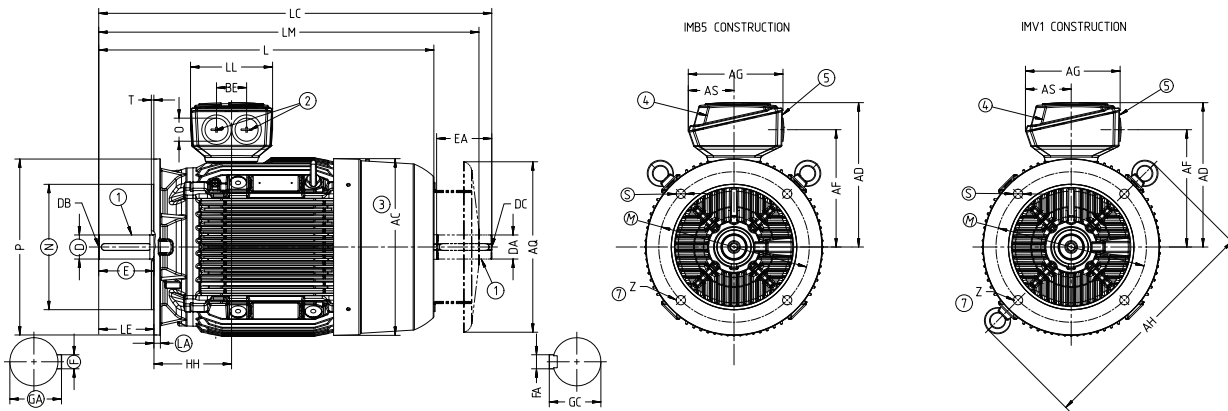

Frame size	No. of poles	AC	AD	AF	AG	AH	AS	AQ	BE	HH	L	LC	LE	LL	LM	O	Shaft extension										Flange																	
																	Drive end					Non-drive end					⊙ Number	LA	M	N	P	S	T	⊙ Z										
																	D	DB	E	F	GA	DA	DC	EA	FA	GC																		
160M	2,4,6										594	730			654																													
160L	2,6	314	267	213	190	396	92	260	60	145	654	790	110	165	714	M40	42	M16	110	12	45	42	M16	110	12	45	F300B	13	300	250	350	19	5	4										
	4										594	730			654																													
180M	2,4										668	784			758																													
180L	4	356	288	234	190	468	92	340	60	155	698	814	110	165	788	M40	48	M16	110	14	51.5	48	M16	110	14	51.5	F300B	13	300	250	350	19	5	4										
	6										668	784			758																													
200L	2,4,6	396	318	259	266	533	112	340	85	164	721	835	110	197	811	M50	55	M20	110	16	59	55	M20	110	16	59	F350B	15	350	300	400	19	5	4										
225S	4										788	903	140		885		60			140	18	64	55	M20	110	16	59																	
225M	2										818	933	110		915		55			110	16	59	48	M16	110	14	51.5	F400B	16	400	350	450	19	5	8									
	4	449	341	282	266	556	112	425	85	164	848	963	140		945																													
	6										788	903	140		885		60			140	18	64	55	M20	110	16	59																	

- ① Shaft extension as per IEC:60072 / IS:1231
- ② 2 Nos. Conduit Entry as per IEC:60423 / IS:14763
- ③ Measured over bolt heads
- ④ Terminal box can be rotated in steps of 90°
- ⑤ Cable End box of Non Detachable type
- ⑥ Flange as per IEC:60072 / IS:2223
- ⑦ No. of fixing holes

Definitive Dimensions:
M,N,S,D,E,F,GA,LA are binding dimensions for all standard motors.
All other dimensions are subject to change.
For Valid dimensions, please contact Regional office in your region.

1LE7 (Frame size 250-315) IMB3-IE2

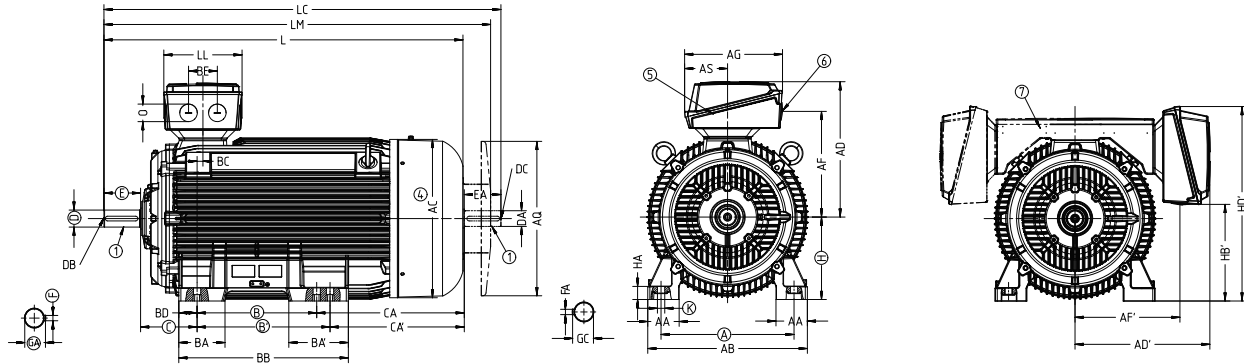

Frame size	No. of poles																					Shaft extension																						
																						Drive end				Non-drive end																		
		A	AA	AB	AC	AD	AD'	AG	AS	AQ	B	B'	BA	BA'	BB	BC	BD	BE	C	CA	CA'	H	HA	AF	HB'	AF'	HD'	K	L	LC	LL	LM	O	D	DB	E	F	GA	DA	DC	EA	FA	GC	
250M	2 4,6	406	100	490	497	410	435	319	145	470	349	NA	102	102	409	24	30	110	168	235	NA	250	40	320	290	345	600	24	887	1002 1032	233	984	①	60 65	②	140	18	64 69	55 60	②	110 140	16 18	59 64	
280S	2 4,6									368	-								267	-								960	1105		1066			65 75		18 20	69 79.5	60 65			64 69			
280M	2 4 6	457	100	540	551	435	435	319	145	525			101	152	479	20	30	110	190		326 216		280	40	345	340	345	655	24	1070 960	1215 1105	233	1176 1066	③	65 75	④	140	18	69 79.5	60 65	②	140	18	64 69
315S	2 4,6									406	-								295	-								1052 1082	1197 1227		1158 1188			65 80		140 170	18 22	69 85	60 70			18 20	64 74.5	
315M	2 4 6	508	120	610	616	515	515	374	164	590			113	170		35			244		409 244		315	50	405	375	405	745	28	1247 1082	1392 1227	299	1353 1188	⑤	80 80	⑥	170	22	85 85	70 70	②	140	18	64 74.5
315L	2 4,6												176	227	648		70			513								1372 1247	1517 1392		1478 1353			65 80		140	18	69 85	60 70			18 20	64 74.5	
	⑧												176	227	648		70			513								1402	1547		1508			80		170	22	85	70			20	74.5	

- ① Shaft extension as per IEC:60072 / IS:1231
- ② Protected Centre hole M20x42
- ③ 2 Nos. Conduit Entry M63x1.5-IEC:60423 / IS:14763
- ④ Measured over bolt heads
- ⑤ Terminal box can be rotated in steps of 90°
- ⑥ Cable End box of Non Detachable type
- ⑦ For Terminal Box on left, view is "mirror image"
- ⑧ For output 200 kW of 4 pole

Definitive Dimensions:
A,B,B',C,H,K,D,E,F,GA are binding dimensions for all standard motors.
All other dimensions are subject to change.
For valid dimensions, please contact Regional office in your region.

1LE7 IE2 (Frame size 250-315) IMB5/V1

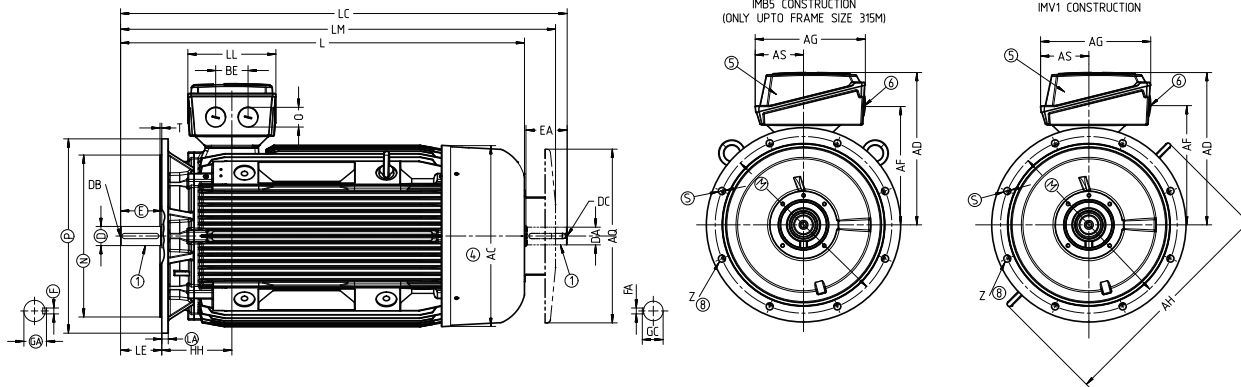

Frame size	No. of poles	AC	AD	AG	AF	AH	AQ	AS	BE	HH	L	LC	LE	LL	LM	O	Shaft extension								Flange									
																	Drive end				Non-drive end				Number	LA	M	N	P	S	T	Z		
																	D	DB	E	F	GA	DA	DC	EA									FA	GC
250M	2	497	410	319	320	620	470	145	110	192	887	1002	140	233	984	③	60	②	140	18	64	55	②	110	16	59	F500B	18	500	450	550	19	5	8
	1032											65					18																	
280S	2	551	435	319	345	672	525	145	110	210	960	1105	140	233	1066	③	65	②	140	18	69	60	②	140	18	64	F500B	18	500	450	550	19	5	8
	1176											75					20																	
280M	4	551	435	319	345	672	525	145	110	210	1070	1215	140	233	1176	③	75	②	140	18	69	60	②	140	18	69	F500B	18	500	450	550	19	5	8
	1066											75					20																	
315S	2	616	515	374	405	780	590	164	110	238	1052	1197	140	299	1158	③	65	②	140	18	69	60	②	140	18	64	F600B	22	600	550	660	24	6	8
	1188											80					170																	
315M	2	616	515	374	405	780	590	164	110	238	1052	1197	140	299	1158	③	65	②	140	18	69	60	②	140	18	64	F600B	22	600	550	660	24	6	8
	1188											80					170																	
315L	4	616	515	374	405	780	590	164	110	238	1247	1392	170	299	1353	③	80	②	140	18	69	60	②	140	18	64	F600B	22	600	550	660	24	6	8
	1188											80					170																	
315L	4,6	616	515	374	405	780	590	164	110	238	1372	1517	170	299	1478	③	65	②	140	18	69	60	②	140	18	64	F600B	22	600	550	660	24	6	8
	1188											80					170																	
315L	4,6	616	515	374	405	780	590	164	110	238	1247	1392	170	299	1353	③	80	②	140	18	69	60	②	140	18	64	F600B	22	600	550	660	24	6	8
	1188											80					170																	
315L	4⑨	616	515	374	405	780	590	164	110	238	1402	1547	170	299	1508	③	80	②	140	18	69	60	②	140	18	64	F600B	22	600	550	660	24	6	8
	1188											80					170																	

- ① Shaft extension as per IEC:60072 / IS:1231
- ② Protected Centre hole M20x42
- ③ 2 Nos. Conduit Entry M63x1.5-IEC:60423 / IS:14763
- ④ Measured over bolt heads
- ⑤ Terminal box can be rotated in steps of 90°
- ⑥ Cable End box of Non Detachable type
- ⑦ Flange as per IEC:60072 / IS:2223
- ⑧ No. of fixing holes
- ⑨ For output 200 kW of 4 pole

Definitive Dimensions:
M,N,S,D,E,F,GA and LA are binding dimensions for all standard motors.
All other dimensions are subject to change.
For Valid dimensions, please contact Regional office in your region.

1LE7 (Frame size 71-132) IMB3-IE3

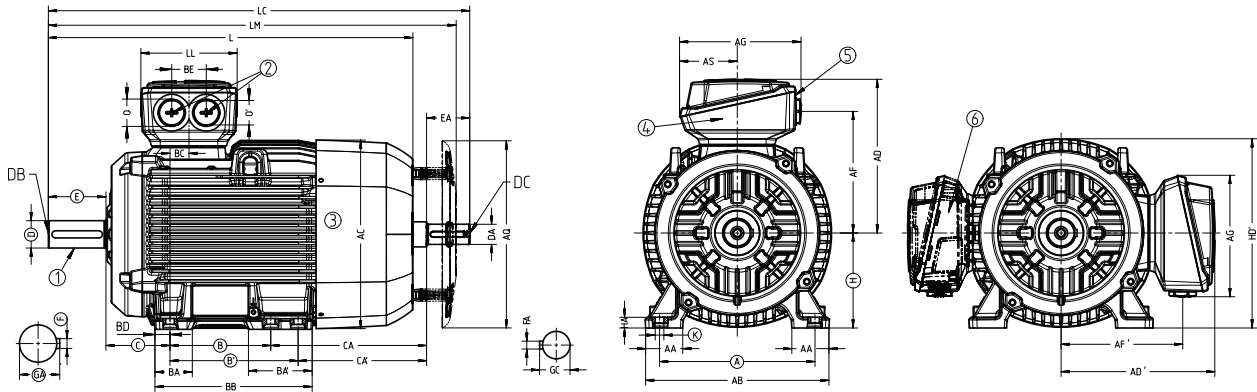

Frame size	No. of poles	Shaft extension																																									
		Drive end													Non-drive end																												
		D	DB	E	F	GA	DA	DC	EA	FA	GC	D	DB	E	F	GA	DA	DC	EA	FA	GC																						
71M	2,4,6,8	112	30.5	134	145	135	NA	111	47.5	125	90	NA	NA	NA	112	29	11	33	45	88	NA	71	8	102	NA	NA	7	248	280	283	89	M16	M25	14	M5	30	5	16	14	M5	30	5	16
80M	2,4,6,8 4,6,8 ^⑩	125	30.5	150	162	140	NA	111	47.5	155	100	NA	NA	NA	122	22.5	11	33	50	112.5 147.5	NA	80	9	107	NA	NA	10	292	328	342.5				19	M6	40	6	21.5	19	M6	40	6	21.5
90S ^⑧	2,4,6,8	140	30.5	168	180	151	NA	111	47.5	155	100	-	36	62	148	33	11	33	56	159	-	90	11	118	NA	NA	10	356	392	405	126	M32	M32	24	M8	50	8	27	19	M6	40	6	21.5
90L ^⑧	2,4,6,8	160	42	196	217	174	163	80.5	195	140	NA	48	48	176	37.5	18	48	63	176 141	NA	100	12	132	132	202	12	425	465	489	28				M10	60	8	31	24	M8	50	8	27	
100L	2,4,6,8 8 ^⑧	190	46	226	239	177	177	163	80.5	195	140	NA	48	48	176	30	18	48	70	185 155	NA	112	15	135	135	226	12	436	476	505	134	M32	M32	28	M10	60	8	31	24	M8	50	8	27
112M	4,8 6	216	53	256	281	215	215	163	80.5	260	140	-	52	89	218	26.5	20	48	89	166.5 216.5	-	132	15	169	169	266	12	409	449	475				38	M12	80	10	41	28	M10	60	8	31
132S	2,8 ⑩2,4,6	216	53	256	281	215	215	163	80.5	260	140	-	52	89	218	26.5	20	48	89	166.5 216.5	-	132	15	169	169	266	12	458	518	535.5	38	M12	80	10	41	28	M10	60	8	31			
132M	4,6	216	53	256	281	215	215	163	80.5	260	140	-	52	89	218	26.5	20	48	89	166.5 216.5	-	132	15	169	169	266	12	508	568	585.5	38	M12	80	10	41	28	M10	60	8	31			
132M	4,6	216	53	256	281	215	215	163	80.5	260	140	-	52	89	218	26.5	20	48	89	166.5 216.5	-	132	15	169	169	266	12	566.5	626.5	637.5	38	M12	80	10	41	28	M10	60	8	31			

- ① Shaft extension as per IEC:60072 / IS:1231
- ② 2 Nos. Conduit Entry as per IEC:60423 / IS:14763
- ③ Measured over bolt heads
- ④ Terminal box can be rotated in steps of 90°
- ⑤ Cable End box of Non Detachable type
- ⑥ For Terminal Box on left, view is "mirror image"
- ⑦ For 0.75 kW (4P) & 0.55 kW (6P) & 0.25 kW (8P) outputs
- ⑧ Eye bolt provided as lifting arrangement
- ⑨ For 0.75 kW (8P) output
- ⑩ For 7.5 kW (2P) output

Definitive Dimensions:
A,B,B',C,H,K,D,E,F,GA are binding dimensions for all standard motors.
All other dimensions are subject to change.
For Valid dimensions, please contact Regional office in your region.

1LE7 (Frame size 71-132) IMB5/IMV1-IE3

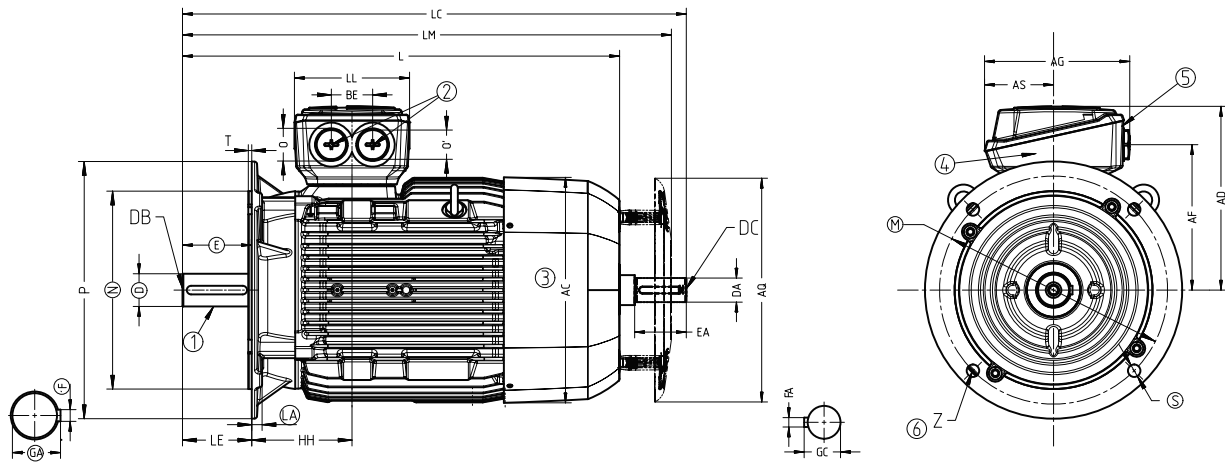

Frame size	No. of poles	AC	AD	AG	AS	AQ	LE	AF	BE	HH	L	LM	LC	LL	O	O'	Shaft extension										Flange							
																	Drive end					Non-drive end					Number	LA	M	N	P	S	T	Z
																	D	DB	E	F	GA	DA	DC	EA	FA	GC								
71M	2,4,6,8	145	135	111	47.5	125	30	102	33	74	248	280	283	89	M16	M25	14	M5	30	5	16	14	M5	30	5	16	F130B	9	130	110	160	10	3.5	4
80M	2,4,6,8	162	140	111	47.5	155	40	107	33	72.5	292	328	342.5				19	M6	40	6	21.5	19	M6	40	6	21.5	F165B	10	165	130	200	12	3.5	4
	4,6,8										327	363	377.5				24	M8	50	8	27	19	M6	40	6	21.5	F165B	10	165	130	200	12	3.5	4
90S	2,4,6,8	180	151	111	47.5	155	50	118	33	89	356	392	405	126	M32	M32	28	M10	60	8	31	24	M8	50	8	27	F215B	11	215	180	250	15	4	4
90L	2,4,6,8										396	432	445				28	M10	60	8	31	24	M8	50	8	27	F215B	11	215	180	250	15	4	4
100L	2,4,6,8	217	174	163	80.5	195	60	132	48	100.5	425	465	489				28	M10	60	8	31	24	M8	50	8	27	F215B	11	215	180	250	15	4	4
112M	4,8										239	177	163	80.5	195	60	135	48	100	436	476	505	28	M10	60	8	31	24	M8	50	8	27	F215B	11
	6	409	449	475	38	M12	80	10	41	28										M10	60	8	31	F265B	12	265	230	300	15	4	4			
132S	2,8	281	215	163	80.5	260	80	169	48	115.5	458	518	535.5	134	M32	M32	38	M12	80	10	41	28	M10	60	8	31	F265B	12	265	230	300	15	4	4
	4,6										508	568	585.5				38	M12	80	10	41	28	M10	60	8	31	F265B	12	265	230	300	15	4	4
132M	4,6										566.5	626.5	637.5																					

- ① Shaft extension as per IEC:60072 / IS:1231
- ② 2 Nos. Conduit Entry as per IEC:60423 / IS:14763
- ③ Measured over bolt heads
- ④ Terminal box can be rotated in steps of 90°
- ⑤ Cable End box of Non Detachable type
- ⑥ No. of fixing holes
- ⑦ For 0.75 kW (4P) & 0.55 kW (6P) & 0.25 kW (8P) outputs
- ⑧ Eye bolt provided as lifting arrangement
- ⑨ For 0.75 kW (8P) output
- ⑩ For 7.5 kW (2P) output

Definitive Dimensions:
A,B,B',C,H,K,D,E,F,GA are binding dimensions for all standard motors.
All other dimensions are subject to change.
For Valid dimensions, please contact Regional office in your region.

1LE7 (Frame size 71-132) IMB14-IE3

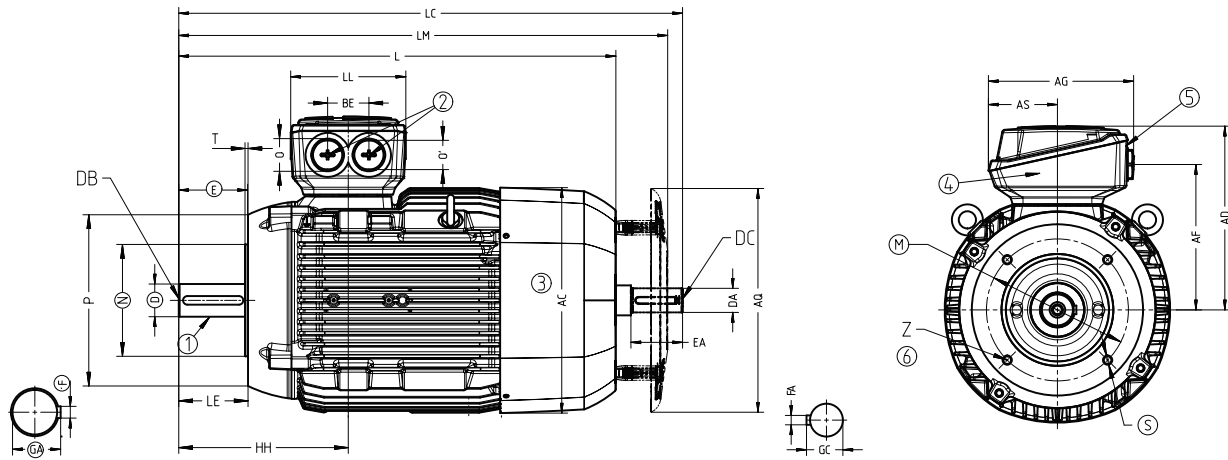

Frame size	No. of poles	AC	AD	AG	AS	AQ	AF	BE	LE	HH	L	LM	LC	LL	O	O'	Shaft extension										IM B14 Flange						
																	Drive end					Non-drive end					⊙ Number	M	N	P	S	T	Z
																	D	DB	E	F	GA	DA	DC	EA	FA	GC							
71M	2,4,6,8	145	135	111	47.5	125	102	33	30	74	248	280	278	89	M16	M25	14	M5	30	5	16	14	M5	30	5	16	F85C	85	70	105	M6	2.5	4
	2,4,6,8 4,6,8⊙	162	140	111	47.5	155	107	33	40	72.5	292	328	342.5				327	363	377.5	19	M6	40	6	21.5	19	M6	40	6	21.5	F100C	100	80	120
90S	2,4,6,8	180	151	111	47.5	155	118	33	50	89	356	392	405	126	M32	M32	24	M8	50	8	27	19	M6	40	6	21.5	F115C	115	95	140	M8	3	4
90L	2,4,6,8										396	432	445				28	M10	60	8	31	24	M8	50	8	27	F130C	130	110	160	M8	3.5	4
100L	2,4,6,8 8⊙	217	174	163	80.5	195	132	48	60	100.5	425	465	489	134	M32	M32	28	M10	60	8	31	24	M8	50	8	27	F130C	130	110	160	M8	3.5	4
	4,8										390	430	454				28	M10	60	8	31	24	M8	50	8	27	F130C	130	110	160	M8	3.5	4
112M	4,8 6	239	177	163	80.5	195	135	48	60	100	436	476	505	134	M32	M32	28	M10	60	8	31	24	M8	50	8	27	F130C	130	110	160	M8	3.5	4
	2,8										409	449	475				38	M12	80	10	41	28	M10	60	8	31	F165C	165	130	200	M10	3.5	4
132S	2,8 ⊙2,4,6	281	215	163	80.5	260	169	48	80	115.5	458	518	535.5	134	M32	M32	38	M12	80	10	41	28	M10	60	8	31	F165C	165	130	200	M10	3.5	4
132M	4,6										508	568	585.5				566.5	626.5	637.5	38	M12	80	10	41	28	M10	60	8	31	F165C	165	130	200

- ① Shaft extension as per IEC:60072 / IS:1231
- ② 2 Nos. Conduit Entry as per IEC:60423 / IS:14763
- ③ Measured over bolt heads
- ④ Terminal box can be rotated in steps of 90°
- ⑤ Cable End box of Non Detachable type
- ⑥ No. of fixing holes
- ⑦ For 0.75 kW (4P) & 0.55 kW (6P) & 0.25 kW (8P) outputs
- ⑧ Eye bolt provided as lifting arrangement
- ⑨ For 0.75 kW (8P) output
- ⑩ For 7.5 kW (2P) output

Definitive Dimensions:
A,B,B',C,H,K,D,E,F,GA are binding dimensions for all standard motors.
All other dimensions are subject to change.
For Valid dimensions, please contact Regional office in your region.

1LE7503 (Frame size 160-225) IMB5/IMV1-IE3

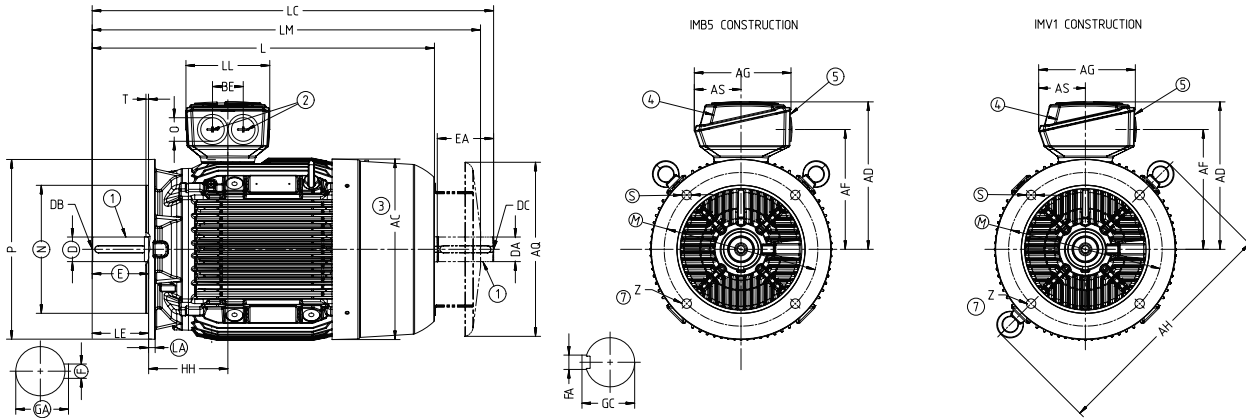

Frame size	No. of poles	AC	AD	AF	AG	AH	AS	AQ	BE	HH	L	LC	LE	LL	LM	O	Shaft extension										Flange							
																	Drive end					Non-drive end					⊙ Number	LA	M	N	P	S	T	⊙ Z
																	D	DB	E	F	GA	DA	DC	EA	FA	GC								
160M	2,4,6,8	314	267	213	190	396	92	260	60	145	594	730	110	165	654	M40	42	M16	110	12	45	42	M16	110	12	45	F300B	13	300	250	350	19	5	4
	⊙2,8⊙										654	790																						
160L	2,4,6,8	356	288	234	190	468	92	340	60	155	668	784	110	165	758	M40	48	M16	110	14	51.5	48	M16	110	14	51.5	F300B	13	300	250	350	19	5	4
180M	2,4										698	814																						
180L	4,8	396	313	259	266	533	112	340	85	164	668	784	110	197	811	M50	55	M20	110	16	59	55	M20	110	16	59	F350B	15	350	300	400	19	5	4
	6										668	784																						
200L	2,4,6,8	449	341	282	266	556	112	425	85	197	848	963	140	197	915	M50	55	M20	110	16	59	48	M16	110	14	51.5	F400B	16	400	350	450	19	5	8
	4										788	903	885																					
225S	4,8	449	341	282	266	556	112	425	85	197	818	933	110	197	915	M50	55	M20	110	16	59	48	M16	110	14	51.5	F400B	16	400	350	450	19	5	8
	8										848	963	945																					
225M	2	449	341	282	266	556	112	425	85	197	818	933	110	197	915	M50	55	M20	110	16	59	48	M16	110	14	51.5	F400B	16	400	350	450	19	5	8
	6,8										848	963	945																					
225M	4	449	341	282	266	556	112	425	85	197	928	1043	140	197	1025	M50	55	M20	110	16	59	48	M16	110	14	51.5	F400B	16	400	350	450	19	5	8
	4										928	1043	1025																					

- ① Shaft extension as per IEC:60072 / IS:1231
- ② 2 Nos. Conduit Entry as per IEC:60423 / IS:14763
- ③ Measured over bolt heads
- ④ Terminal box can be rotated in steps of 90°
- ⑤ Cable End box of Non Detachable type
- ⑥ Flange as per IEC:60072 / IS:2223
- ⑦ For 15 kW (2P) output
- ⑧ For 5.5 kW (8P) output

Definitive Dimensions:
M,N,S,D,E,F,GA,LA are binding dimensions for all standard motors.
All other dimensions are subject to change.
For Valid dimensions, please contact Regional office in your region.

1LE7 (Frame size 250-315) IMB3-IE3

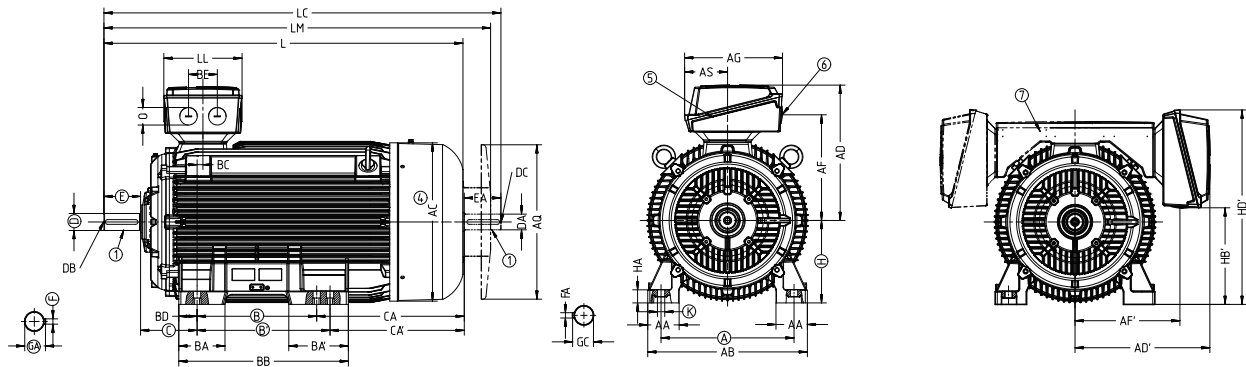

Frame size	No. of poles	①																				Shaft extension																				
		A	AA	AB	AC	AD	AD'	AG	AS	AQ	B	B'	BA	BA'	BB	BC	BD	BE	C	CA	CA'	H	HA	HA'	AF	HB'	AF'	HD'	K	L	LC	LL	LM	O	Drive end			Non-drive end				
250M	2	406	100	490	497	410	435	319	145	470	349	NA	102	102	409	24	30	110	168	235	-	250	40	320	290	345	600	24	887	1002	233	984	② 60	② 140	18	64	55	② 110	16	59		
	4,6,8																																		65		69	60	140	18	64	
280S	2	457	100	540	551	435	435	319	145	525	368	-	101	152	479	20	30	110	190	267	-	280	40	345	340	345	655	24	960	1105	233	1066	② 65	② 140	18	69	60	② 140	18	64		
	4,6,8																																		75		20	79.5	65		69	
280M	2										-	419									-	326							1070	1215		1176	65		18	69	60			64		
	4										-	368																	960	1105		1066	75		20	79.5	65			69		
315S	2	508	120	610	616	515	515	374	164	590	406	-	113	170	527	22	35	110	216	295	-	315	50	405	375	405	745	28	1052	1197	299	1158	② 65	② 140	18	69	60	② 140	18	64		
	4,6,8																																		80	170	22	85	70		20	74.5
315M	2										457	-			578						409	-							1217	1362		1323	65	140	18	69	60			18	64	
	4,6,8																																		80	170	22	85	70			20
315L	2										-	508	176	227	648		70				-	513							1372	1517		1478	65	140	18	69	60			18	64	
	4,6																																		80	170	22	85	70			20
	④,⑥,8												113	170	578		35					358							1247	1392		1353	80	170	22	85	70			20	74.5	

- ① Shaft extension as per IEC:60072 / IS:1231
- ② Protected Centre hole M20x42
- ③ 2 Nos. Conduit Entry M63x1.5-IEC:60423 / IS:14763
- ④ Measured over bolt heads
- ⑤ Terminal box can be rotated in steps of 90°
- ⑥ Cable End box of Non Detachable type
- ⑦ For Terminal Box on left, view is "mirror image"
- ⑧ For output 160 kW of 4 pole
- ⑨ For output 110 kW of 6 pole

Definitive Dimensions:
A,B,B',C,H,K,D,E,F,GA are binding dimensions for all standard motors.
All other dimensions are subject to change.
For Valid dimensions, please contact Regional office in your region.

1LE7 (Frame size 250-315) IMB5/V1-IE3

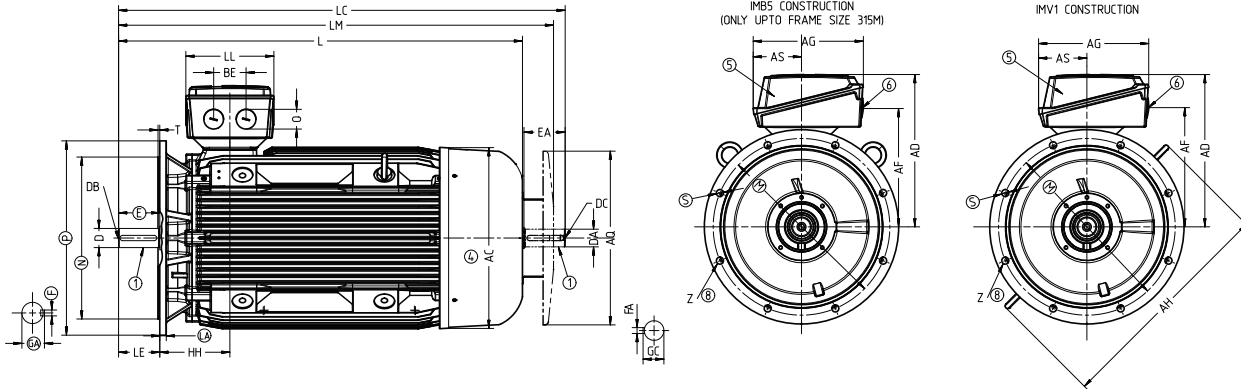

Frame size	No. of poles	① AC	AD	AG	AF	AH	AQ	AS	BE	HH	L	LC	LE	LL	LM	O	Shaft extension										Flange								
																	Drive end					Non-drive end					⑦ Number	LA	M	N	P	S	T	⑧ Z	
																	D	DB	E	F	GA	DA	DC	EA	FA	GC									
250M	2	497	410	319	320	620	470	145	110	192	887	1002	140	233	984	③	60	②	140	18	64	55	②	110	16	59	F500B	18	500	450	550	19	5	8	
	1032											65					69				60	140			18	64									
280S	2	551	435	319	345	672	525	145	110	210	960	1105	140	233	1176	③	65	②	140	18	69	60	②	140	18	64	F500B	18	500	450	550	19	5	8	
	1070											75					20			79.5	65	69			69										
280M	4	551	435	319	345	672	525	145	110	210	960	1105	140	233	1176	③	65	②	140	18	69	60	②	140	18	64	F500B	18	500	450	550	19	5	8	
	1070											75					20			79.5	65	69			69										
315S	2	616	515	374	405	780	590	164	110	238	1052	1197	140	299	1353	③	65	②	140	18	69	60	②	140	18	64	F600B	22	600	550	660	24	6	8	
	1082											80					170			22	85	70			20	74.5									
315M	2	616	515	374	405	780	590	164	110	238	1217	1362	140	299	1323	③	65	②	140	18	69	60	②	140	18	64	F600B	22	600	550	660	24	6	8	
	1247											80					170			22	85	70			20	74.5									
315L	2	616	515	374	405	780	590	164	110	238	1372	1517	140	299	1478	③	65	②	140	18	69	60	②	140	18	64	F600B	22	600	550	660	24	6	8	
	1402											80					170			22	85	70			20	74.5									
④4, ⑩6, 8	4,6	616	515	374	405	780	590	164	110	238	1247	1547	140	299	1508	③	80	②	140	170	22	85	70	②	140	20	74.5	F600B	22	600	550	660	24	6	8
	1247											80					170			22	85	70	20			75.5									

- ① Shaft extension as per IEC:60072 / IS:1231
- ② Protected Centre hole M20x42
- ③ 2 Nos. Conduit Entry M63x1.5-IEC:60423 / IS:14763
- ④ Measured over bolt heads
- ⑤ Terminal box can be rotated in steps of 90°
- ⑥ Cable End box of Non Detachable type
- ⑦ Flange as per IEC:60072 / IS:2223
- ⑧ No. of fixing holes
- ⑨ For output 160 kw of 4 pole
- ⑩ For output 110 kw of 6 pole

Definitive Dimensions:
M,N,S,D,E,F,GA and LA are binding dimensions for all standard motors.
All other dimensions are subject to change.
For Valid dimensions, please contact Regional office in your region.

1LE7504 (Frame size 180-225) IMB3

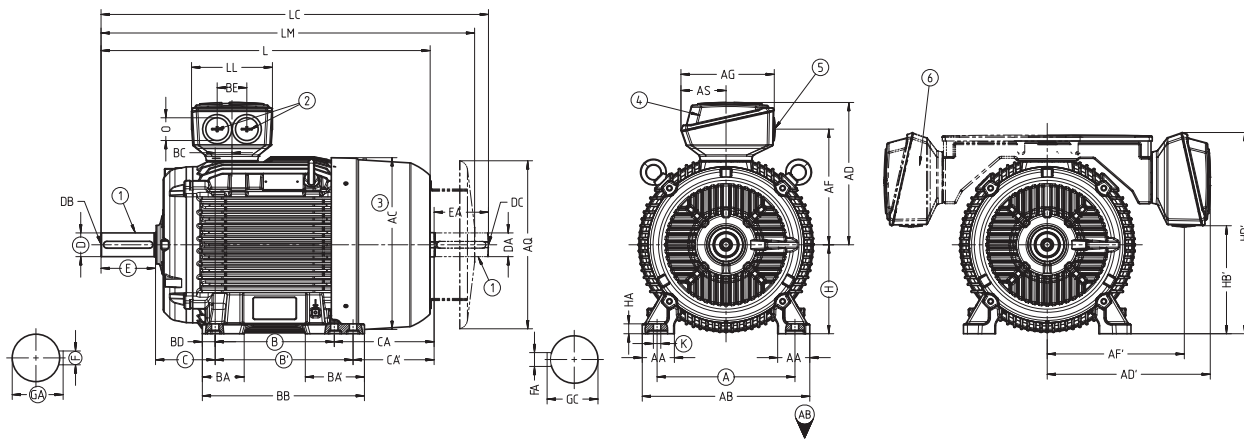

Frame size	No. of poles																				Shaft extension																												
		A	AA	AB	AC	AD	AD'	AG	AS	AQ	B	B'	BA	BA'	BB	BC	BD	BE	C	CA	CA'	H	HA	AF	HB'	AF'	HD'	K	L	LC	LL	LM	O	Drive end				Non-drive end											
		D	DB	E	F	GA	DA	DC	EA	FA	GC																																						
180M	2																				232	-							698	814	788																		
	4	279	65	339	356	288	330	190	92	340	241	-	85	120	328	34	26	60	121	292	-	180	20	234	220	276	408	14.5	758	874	165	848	M40	48	M16	110	14	51.5	48	M16	110	14	51.5						
180L	4																				-	279							878	994	968																		
200L	2	318	70	378	396	318	363	265	112	340	305	NA	104	104	355	31	25	85	133	177	287	NA	200	25	259	209	304	471	18.5	721	835	811	921	M50	55	M20	110	16	59	55	M20	110	16	59					
	⑦,4																				831	945	921																										
225S	4																				286	-							358	-							928	1043	1025		60	140	18	64	55	M20	110	16	59
225M	2	356	80	436	449	341	363	266	112	425	-	311	93	118	361	15	25	85	149	-	333	225	34	282	257	304	519	18.5	898	1013	197	995	M50	55	M20	110	16	59	48	M16	110	14	51.5						
	4																				-	-							928	1043	1025		60	140	18	64	55	M20	110	16	59								

- ① Shaft extension as per IEC:60072 / IS:1231
- ② 2 Nos. Conduit Entry as per IEC:60423 / IS:14763
- ③ Measured over bolt heads
- ④ Terminal box can be rotated in steps of 90°
- ⑤ Cable End box of Non Detachable type
- ⑥ For Terminal Box on left, view is "mirror image"
- ⑦ For 37 kW(2PO output)

Definitive Dimensions:
 A,B,B',C,H,K,D,E,F,GA are binding dimensions for all standard motots.
 All other dimensions are subject to change.
 For Valid dimensions, Please contact Regional office in your region.

1LE7 (Frame size 250-315) IMB3-IE4

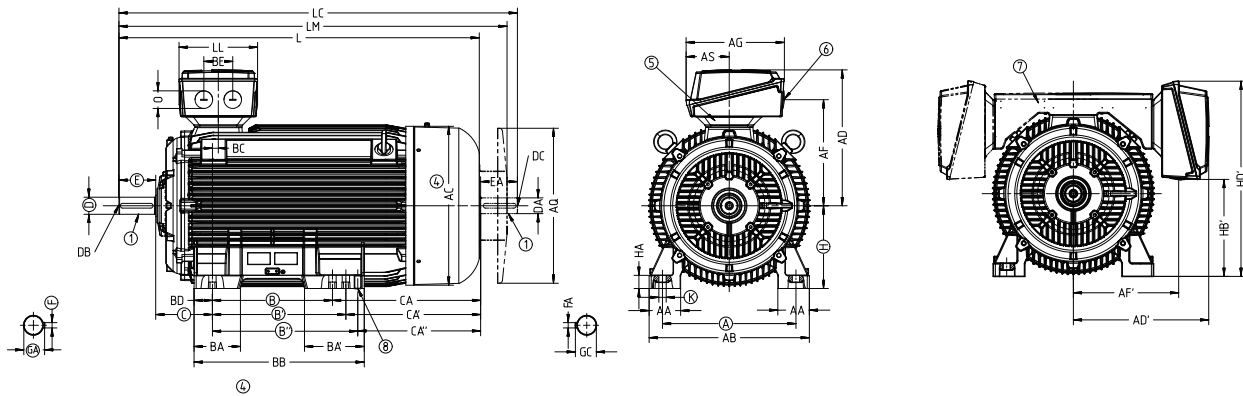

Frame size	No. of poles	①																									Shaft extension																																																					
		A	AA	AB	AC	AD	AD'	AG	AS	AQ	B	B'	B''	BA	BA'	BB	BC	BD	BE	C	CA	CA'	CA''	H	HA	AF	HB'	AF'	HD'	K	L	LC	LL	LM	O	Drive end		Non-drive end																																										
		D	DB	E	F	GA	DA	DC	EA	FA	GC	D	DB	E	F	GA	DA	DC	EA	FA	GC	D	DB	E	F	GA	DA	DC	EA	FA	GC	D	DB	E	F	GA	DA	DC	EA	FA	GC																																							
250M	2	406	100	490	497	410	435	319	145	470	349	NA	NA	102	102	409	24	30	110	168	305	-	NA	250	40	320	290	345	600	24	957	1072	233	1054	②	60	②	140	18	64	55	②	110	16	59	65	69	60	140	18	64	55	②	110	16	59	65	69	60	140	18	64	55	②	110	16	59													
	4,6																																																																															
280S	2	457	100	540	551	435	435	319	145	525	368	-	NA	101	152	479	20	30	110	190	267	-	NA	280	40	345	340	345	655	24	960	1105	233	1066	②	65	②	140	18	69	60	②	140	18	64	75	20	79.5	65									75	20	79.5	65								75	20	79.5	65								
	4																					377																																																										
	6																					267																																																										
280M	2																																																																															
	4,6																																																																															
315S	2	508	120	610	616	515	515	374	164	590	406	-	-	113	225																					②	65	②	140	18	69	60	②	140	18	64	75	20	79.5	65									75	20	79.5	65								75	20	79.5	65							
	4,6																																																																															
315M	2																																																																															
	4,6																																																																															
315L	2																																																																															
	④,⑥																																																																															
	⑥																																																																															

- ① Shaft extension as per IEC:60072 / IS:1231
- ② Protected Centre hole M20x42
- ③ 2 Nos. Conduit Entry M63x1.5-IEC:60423 / IS:14763
- ④ Measured over bolt heads
- ⑤ Terminal box can be rotated in steps of 90°
- ⑥ Cable End box of Non Detachable type
- ⑦ For Terminal Box on left, view is "mirror image"
- ⑧ Applicable only fo FS3155

Definitive Dimensions:
A,B,B',C,H,K,D,E,F,GA are binding dimensions for all standard motors.
All other dimensions are subject to change.
For Valid dimensions, please contact Regional office in your region.

1LE7 (Frame size 250-315) IMB5/V1-IE4

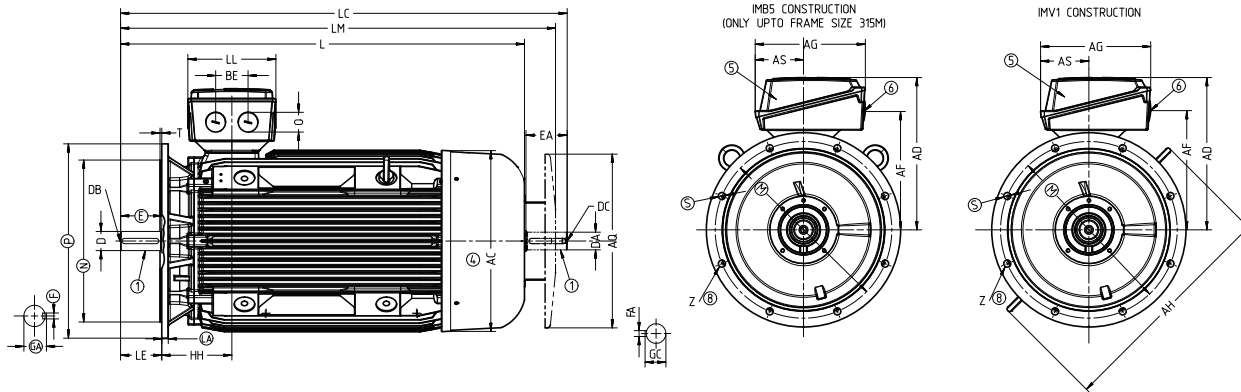

Frame size	No. of poles	①	Shaft extension																Flange																	
			AC	AD	AG	AF	AH	AQ	AS	BE	HH	L	LC	LE	LL	LM	O	Drive end	Non-drive end						②	LA	M	N	P	S	T	③	Z			
																			D	DB	E	F	GA	DA	DC	EA	FA	GC								
250M	2	4,6	497	410	319	320	620	470	145	110	192	957	1072	140	233	1054	③	60	②	140	18	64	55	④	110	16	59	F5008	18	500	450	550	19	5	8	
280S	2	4,6	551	435	319	345	672	525	145	110	210	960	1105	140	233	1066	③	65	②	140	18	69	60	④	140	18	64	F5008	18	500	450	550	19	5	8	
	4											1070	1215			1176		75		20	79.5	65					69									
	6											960	1105			1066																				
280M	2	4,6										1070	1215			1176		65		18	69	60					64									
	4,6																	75		20	79.5	65					69									
	6,8											960	1105			1066		75		20	79.5	65					69									
315S	2	4,6	616	515	374	405	780	590	164	110	238	1217	1362	140	299	1323	③	65	②	140	18	69	60	④	140	18	64	F6008	22	600	550	660	24	6	8	
	4,6											1247	1392	170		1353		80		170	22	85	70		20	74.5										
315M	2	4,6										1217	1362	140		1323		65		140	18	69	60			18	64									
	4,6											1247	1392	170		1353		80		170	22	85	70		20	74.5										
315L	2	④, 6⑩										1372	1517	140		1478		65		140	18	69	60			18	64									
	④, 6⑩											1402	1547	170		1508		80		170	22	85	70			20	74.5									

- ① Shaft extension as per IEC:60072 / IS:1231
- ② Protected Centre hole M20x42
- ③ 2 Nos. Conduit Entry M63x1.5-IEC:60423 / IS:14763
- ④ Measured over bolt heads
- ⑤ Terminal box can be rotated in steps of 90°
- ⑥ Cable End box of Non Detachable type
- ⑦ Flange as per IEC:60072 / IS:2223
- ⑧ No. of fixing holes

Definitive Dimensions:
M,N,S,D,E,F,GA and LA are binding dimensions for all standard motors.
All other dimensions are subject to change.
For Valid dimensions, please contact Regional office in your region.

SIMOTICS-1LE7

13 th	← Position in the MLFB	Motor Protection
A	3x PTC thermistors for tripping (Class F)	1x Thermal protection
B	6x PTC thermistors for tripping (Class F)	3x PTC thermistors for tripping (Class F)
C	6x PTC thermistors - 3x for alarm and 3x for tripping (Class F)	3x PTC thermistors - 3x for alarm and 3x for tripping (Class F)
H	6x PT100 resistance thermometers in stator winding - 2 wire	6x PT100 resistance thermometers in stator winding - 2 wire
J	1x Temperature sensor - PT1000	1x Temperature sensor - PT1000
K	2x Temperature sensor - PT1000	2x Temperature sensor - PT1000
Z	Q18	6x PT100 resistance thermometers in stator winding - 3 wire from sensor
Z	Q28	6x PT100 resistance thermometers in stator winding - 3 wire from sensor
Z	Q3A	3x Bi-metallic sensors for trip operation (Thermostats)
Z	Q9A	6x Bi-metallic sensors (3x for alarm, 3x for tripping) (Thermostats)
B	-Z-Q11	Additional 3x PTC thermistors for tripping
B or C	-Z-Q9D	Additional to Position 15 (Value of Position 15 = B or C with or without Q11)
B or C	-Z-Q9D	Class F PTC thermistors (Alum. 130°C, Trip 140°C)

Shaft Height (Position 8 & 9)						
8 th	9 th	A	B	C	D	E
0	1	56	63	71	80	90
1	100	112	132	160	180	180
2	200	225	250	280	-	-
3	315	-	-	-	-	-

Design & Efficiency Variant		IEC (Efficiency Class)	
6 th	7 th	50Hz	60Hz P60
0	1	Single speed - IE2 50Hz	IE2 or IE1
0	3	Single speed - IE3 50Hz	IE3 or IE2
0	4	Single speed - IE4 50Hz	IE4 or IE3
9	1	Single speed - IE2 50Hz Premium Insulation scheme	IE2 or IE1
9	3	Single speed - IE3 50Hz Premium Insulation scheme	IE3 or IE2
9	4	Single speed - IE4 50Hz Premium Insulation scheme	IE4 or IE3

Note: Some motors with 9 in 6th position may have a lower efficiency class than depicted by 7th position.

Main Series (Low Voltage Motors - Totally Enclosed - Surface Cooled)			
1 st	2 nd	3 rd	4 th
L	E	7	7
TEC (IEC11)			
TEC (IEC15) as per IPQ			

Position in the MLFB
Code suffixes
Type of digit in the position
MLFB

Note:
Motors with a "0" in position no. 6 of the MLFB are provided with a standard insulation scheme which make them even suitable for converter / trip operation as below:
 $U_N \leq 480V$ for frames 71 to 225
 $U_N \leq 500V$ for frames 250 to 315

Material of Housing & Design	
5 th	← Position in the MLFB
5	Cast iron - standard output
6	Cast iron - reduced output - adapted winding

The 16 digit MLFB Structure for Kalva Make IEC Motors

The New 16 digit MLFB Structure for IEC Cage Induction Motors made in Kalva has been explained here. This chart has been deliberately kept simple for better and easier understanding of the MLFB concept and therefore not all cases may be covered to avoid complicating matters by giving exhaustive information. Only the certain typical values of each digit have been considered as this chart is only to facilitate easy understanding of the new 16 digit structure of the MLFB. For further details and related codes please refer appropriate reference material.

Important: It should be noted that all of the represented MLFB combinations may not be realisable. This chart has been devised to serve as a guide to assist in understanding the MLFB of an existing motor and should not be used to build a new MLFB at user end.

Reference Document Bais: 6285731-0A030-0A40 - Structuring of the 16 digit order number for standard motors 1LE, 1MB and 1PC of SAG. There are certain modification w.r.t. Indian market requirement.

Example
1 11E7503-2CB23-5IB6-Z Q9D-B50
1LE
7
5
0
3
2C
B
2
3-5
J
B
5
Option Z

1LE on top as viewed from DE
(Q9D Class B PFC) + P50 (One size larger T Box)

Important:
For motors in frames 71 - 225 when required for a voltage $U_N > 480V$, an enquiry with the works is necessary.

All 1LE76 and 60 Hz motors which are delivered on or after 1st July 2021 will not carry CE mark.
All 8 pole motors up to frame size 225 will not carry CE mark.

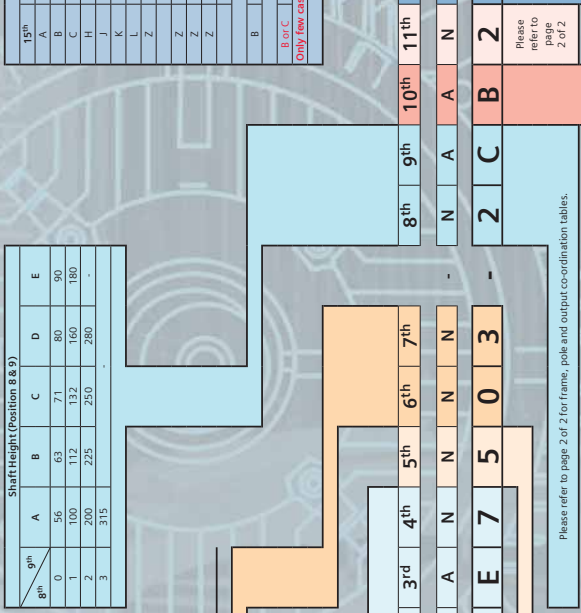

Please refer to page 2 of 2 for frame, pole and output co-ordination tables.

No. of Poles	
10 th	← Position in MLFB
A	2
B	4
C	6
D	8

Voltage Code			
Only some generally required codes shown. For details consult BD.			
Position 12 & 13	Frequency 50Hz	Position 12 & 13 Standard 50Hz Power	Position 12 & 13
18	200VA	(0.75kW)	90
21	230VA	380VA	90
22	230VA	380VA	90
22	250VA	400VA	90
23	240VA	415VA	90
27	288VA	500VA	90
32	360VA	660VA	90
33	380VA	600VA	90
34	400VA	690VA	90
35	415VA	(720VA)	90
36	440VA	-	-
37	460VA	-	-
38	480VA	-	-
40	500VA	(660VA)	90
41	525VA	1000VA	90
43	660VA	-	-
46	660VA	-	-
47	690VA	-	-

90 - with 10% for any other voltage other than those covered above.
Blue bars - the ones are the ones being considered currently to be offered with "defined" Voltage Code.
Brown letters in light yellow background will be presently offered with 9-0 and MTV.
Note: Not all voltage codes may be possible for MLEB5 = 5 or 6

Terminal Box Position	
16 th	← Position in the MLFB
4	Terminal box on TOP
5	Terminal box on RHS
6	Terminal box on LHS
7	Terminal box at bottom (only for horizontal constructions without feet)

Construction Code	
14 th	← Position in the MLFB
A	IM B3, IM B6, IM B7, IM B8, IM V5, IM V6, (stamped IM B3)
B	IM V5 / IM 1011 (for frames up to 315L only)
C	IM V6 / IM 1031 (for frames up to 315L only)
D	IM V7 / IM 3631 standard flange (for frames up to 132M only)
E	IM B5 / IM 3001, IM V1, IM V3, (stamped IM B5) flange (up to 15M only)
F	IM V1 / IM 3011 flange
G	IM V3 / IM 3031 flange (for frames up to 315M only)
H	IM B35 / IM 2001 flange
K	IM B14 / IM 3601, IM V19 / IM V19 / IM V18 / IM 3611 (stamped IM B14) standard flange (for frames up to 132M only)
L	IM V19 / IM 3631 standard flange (for frames up to 132M only)
M	IM V19 / IM 3611 standard flange (for frames up to 132M only)
N	IM B34 / IM 2101 Standard flange (for frames up to 132M only)
T	IM B6 / IM 1051 (for frames up to 315L only)
U	IM B7 / IM 1061 (for frames up to 315L only)
V	IM B8 / IM 1071 (for frames up to 315L only)
W	IM V35
Y	IM V36 (IM V35 when used with B50) (frames up to 315L only)

Position in the MLFB
Code suffixes
Type of digit in the position

MLFB

5th	Material of Housing & Design
4th	Position in the MLFB
3rd	Cast Iron - standard output
2nd	Cast Iron - reduced output - adapted winding

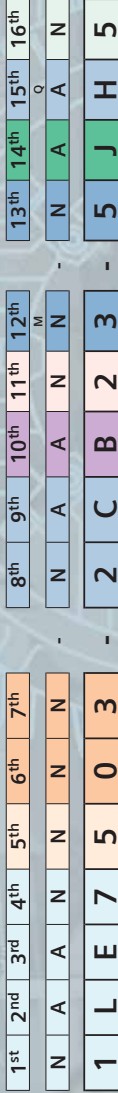

SIMOTICS-1LE7

Note:
Motors with a "0" in position no. 6 of the MLFB are provided with a standard insulation scheme which makes them even suitable for converter-fed operation as below:
U_N = 480V for frames 71 to 225
U_N = 500V for frames 250 to 315

Important:
For motors in frames 71 - 225 when required for a voltage U_N > 480V, an enquiry with the works is necessary.

For 1LE75

Frame Size	8th & 9th Position	No. of Poles	Construction Length (Output assignment for Standard output versions=single speed motors)					
			0	1	2	3	4	5
Code	SH	10 th Position	Length M			Length L		
0C	71	A 2	0.37 kW	0.25 kW	0.37 kW	0.55 kW		
		B 4	0.25 kW	0.37 kW	0.55 kW			
		C 6	0.18 kW	0.25 kW	0.37 kW	0.55 kW		
		D 8	0.12 kW	0.18 kW	0.25 kW	0.37 kW		
0D	80	A 2	0.75 kW	1.1 kW				
		B 4	0.55 kW	0.75 kW				
		C 6	0.37 kW	0.55 kW				
		D 8	0.18 kW	0.25 kW				
0E	90	A 2	1.5 kW	2.2 kW				
		B 4	1.1 kW	1.5 kW				
		C 6	0.75 kW	1.1 kW				
		D 8	0.37 kW	0.55 kW				
1A	100	A 2	7.5 kW	11 kW				
		B 4	5.5 kW	7.5 kW				
		C 6	3.7 kW	5.5 kW				
		D 8	2.2 kW	3.7 kW				
1B	112	A 2	3.7 kW	5.5 kW				
		B 4	2.2 kW	3.7 kW				
		C 6	1.5 kW	2.2 kW				
		D 8	0.9 kW	1.5 kW				
1C	132	A 2	7.5 kW	11 kW				
		B 4	5.5 kW	7.5 kW				
		C 6	3.7 kW	5.5 kW				
		D 8	2.2 kW	3.7 kW				
1D	160	A 2	11 kW	15 kW				
		B 4	7.5 kW	11 kW				
		C 6	5.5 kW	7.5 kW				
		D 8	3.7 kW	5.5 kW				
1E	180	A 2	18.5 kW	22 kW				
		B 4	13 kW	15 kW				
		C 6	9 kW	11 kW				
		D 8	5.5 kW	7.5 kW				
2A	200	A 2	30 kW	37 kW				
		B 4	22 kW	27 kW				
		C 6	15 kW	18.5 kW				
		D 8	9 kW	11 kW				
2B	225	A 2	45 kW	55 kW				
		B 4	30 kW	37 kW				
		C 6	22 kW	27 kW				
		D 8	15 kW	18.5 kW				
2C	250	A 2	55 kW	65 kW				
		B 4	37 kW	45 kW				
		C 6	27 kW	33 kW				
		D 8	18.5 kW	22 kW				
2D	280	A 2	75 kW	90 kW				
		B 4	55 kW	65 kW				
		C 6	45 kW	55 kW				
		D 8	30 kW	37 kW				
3A	315	A 2	160 kW	192 kW				
		B 4	110 kW	132 kW				
		C 6	80 kW	96 kW				
		D 8	55 kW	66 kW				

For 1LE76

Frame Size	8th & 9th Position	No. of Poles	Construction Length (Output assignment for reduced output versions=single speed motors)					
			0	1	2	3	4	5
Code	SH	10 th Position	Length M			Length L		
0C	71	A 2	0.25 kW	0.37 kW	0.55 kW			
		B 4	0.18 kW	0.25 kW	0.37 kW			
		C 6	0.12 kW	0.18 kW	0.25 kW			
		D 8	0.08 kW	0.12 kW	0.18 kW			
0D	80	A 2	0.55 kW	0.75 kW				
		B 4	0.37 kW	0.55 kW				
		C 6	0.25 kW	0.37 kW				
		D 8	0.12 kW	0.18 kW				
0E	90	A 2	1.1 kW	1.5 kW				
		B 4	0.75 kW	1.1 kW				
		C 6	0.55 kW	0.75 kW				
		D 8	0.37 kW	0.55 kW				
1A	100	A 2	7.5 kW	11 kW				
		B 4	5.5 kW	7.5 kW				
		C 6	3.7 kW	5.5 kW				
		D 8	2.2 kW	3.7 kW				
1B	112	A 2	3.7 kW	5.5 kW				
		B 4	2.2 kW	3.7 kW				
		C 6	1.5 kW	2.2 kW				
		D 8	0.9 kW	1.5 kW				
1C	132	A 2	7.5 kW	11 kW				
		B 4	5.5 kW	7.5 kW				
		C 6	3.7 kW	5.5 kW				
		D 8	2.2 kW	3.7 kW				
1D	160	A 2	11 kW	15 kW				
		B 4	7.5 kW	11 kW				
		C 6	5.5 kW	7.5 kW				
		D 8	3.7 kW	5.5 kW				
1E	180	A 2	18.5 kW	22 kW				
		B 4	13 kW	15 kW				
		C 6	9 kW	11 kW				
		D 8	5.5 kW	7.5 kW				
2A	200	A 2	30 kW	37 kW				
		B 4	22 kW	27 kW				
		C 6	15 kW	18.5 kW				
		D 8	9 kW	11 kW				
2B	225	A 2	45 kW	55 kW				
		B 4	30 kW	37 kW				
		C 6	22 kW	27 kW				
		D 8	15 kW	18.5 kW				
2C	250	A 2	55 kW	65 kW				
		B 4	37 kW	45 kW				
		C 6	27 kW	33 kW				
		D 8	18.5 kW	22 kW				
2D	280	A 2	75 kW	90 kW				
		B 4	55 kW	65 kW				
		C 6	45 kW	55 kW				
		D 8	30 kW	37 kW				
3A	315	A 2	160 kW	192 kW				
		B 4	110 kW	132 kW				
		C 6	80 kW	96 kW				
		D 8	55 kW	66 kW				

The 16 digit MLFB Structure for Kalva Make IEC Motors
The New 16 digit MLFB Structure for IEC Cage Induction Motors made in Kalva has been explained here.
This chart has been deliberately kept simple for better and easier understanding of the MLFB concept and therefore not all cases may be covered to avoid complicating matters by giving exhaustive information. Only the certain typical values of each digit have been considered as this chart is only to facilitate easy understanding of the new 16 digit structure of the MLFB. For further details and related codes please refer appropriate reference material.
Important: It should be noted that all of the represented MLFB combinations may not be realisable. This chart has been devised to serve as a guide to assist in understanding the MLFB of an existing motor and should not be used to build a new MLFB at user end.
Reference Document Basis: 6285731-0A030-0AA0 - Structuring of the 16 digit order number for standard motors 1LE, 1MB and 1PC of SAG. There are certain modification w.r.t. Indian market requirement.

- Examples**
- 1 1LE7603-2CB23-4JC5-Z, Q90-B50
 - 7 IEC motor made in India
 - 6 Cast Iron Housing - reduced output - adapted wdg.
 - 0 Single-Speed Motor
 - 3 Efficiency class IE 3 as per IS:12615-2011
 - 2C Shaft Height 250
 - B 4Pole
 - 2 Frame length M, 55kW
 - 3-4 160D, 50Hz
 - 8 3xPTC for alarm, 3x PTC for trip
 - 5 T. Base on BMS as viewed from DE
 - Option Z: Q90 (Class B PTC) + B50 (One size larger L, Box)

IE4 motors are currently possible in FS 180-315.
8 pole motors are possible in IE3 only.

All 1LE76 and 60 Hz motors which are delivered on or after 1st July 2021 will not carry CE mark.
All 8 pole motors up to frame size 225 will not carry CE mark.

Authorised Channel Partner



SALOC Technologies Pvt. Ltd.,

#274/14, New Guddada halli, Mysore Road,
Bangalore - 560026, Karnataka .

Phone : 91-80-2675 5000

Mobile / WhatsApp : 91-98454 55258 / 96864 47828

Mail to : sales@saloc.in, surendran@saloc.in

Website : www.saloc.in

Siemens Limited
Digital Industries
Motion Control : Low Voltage Motors
R&D Technology Centre
Thane Belapur Road, Airoli Node
Navi Mumbai - 400 708
Fax: +91 22 33265504
E-mail: motors.in@siemens.com

Order No.: 111392954
DI-LVM-CAT-1001-2023

www.siemens.co.in

For more information call us on 1800 209 1800
For Life Cycle Support of Products, Systems and
Solutions call us on 1800 209 0987

Product upgradation is a continuous process. Hence,
data in this catalogue is subject to change without prior
notice. For the latest information, please get in touch
with our Sales Offices.